



FLORISSANT CITY COUNCIL AGENDA
City Hall
955 rue St. Francois
Monday, February 13, 2017
7:30 PM
Karen Goodwin, MMC/MRCC



I. PLEDGE OF ALLEGIANCE

II. ROLL CALL OF MEMBERS

III. APPROVAL OF MINUTES

- Meeting Minutes of January 23, 2017

IV. HEARING FROM CITIZENS

(Speaker cards are available at the entrance to the Council Chambers)

V. COMMUNICATIONS

- 1 Letter received January 19, 2017 received from Mandy Ryan regarding the repeal of the pit bull ban
- 2 Email dated January 23, 2017 from Gail Scarfino regarding the repeal of the pit bull ban
- 3 Email dated January 23, 2017 from Vickie Rolfes regarding the repeal of the pit bull ban
- 4 Email dated January 23, 2017 from Amy Newton regarding the repeal of the pit bull ban
- 5 Email dated January 23, 2017 from Erin Berghold regarding the repeal of the pit bull ban
- 6 Email dated January 23, 2017 from Heather Dye regarding the repeal of the pit bull ban
- 7 Email dated January 23, 2017 from Brittany Schleicher regarding the repeal of the pit bull ban
- 8 Email dated January 24, 2017 from Andrea Castleberry regarding the repeal of the pit bull ban
- 9 Email dated January 24, 2017 from Laura Wichlinski regarding the repeal of the pit bull ban
- 10 Email dated January 24, 2017 from Mindy Boyer regarding the repeal of the pit bull ban
- 11 Email dated January 24, 2017 from Connie Nolan regarding the repeal of the pit bull ban
- 12 Email dated January 24, 2017 from Sandra Link regarding the repeal of the pit bull ban
- 13 Email dated January 25, 2017 from Becky Keesling regarding the repeal of the pit bull ban
- 14 Email dated January 25, 2017 from Debbie Causevic regarding the repeal of the pit bull ban
- 15 Email dated January 25, 2017 from Melissa Jeffery regarding the repeal of the pit bull ban
- 16 Email dated January 25, 2017 from Tamara Vastine regarding the repeal of the pit bull ban

- 17 Email dated January 25, 2017 from Angie Schaefer regarding the repeal of the pit bull ban
- 18 Email dated January 26, 2017 from Carl Hughes regarding the repeal of the pit bull ban
- 19 Email dated January 25, 2017 from the Staff of Slem's Pet Care regarding the repeal of the pit bull ban
- 20 Email dated January 25, 2017 from Donna Slemmer regarding the repeal of the pit bull ban
- 21 Email dated January 26, 2017 from Shawna Walker regarding the repeal of the pit bull ban
- 22 Email dated January 26, 2017 from Cheryl Genail regarding the repeal of the pit bull ban
- 23 Email dated January 30, 2017 from Gail Howell regarding the repeal of the pit bull ban
- 24 Email dated January 30, 2017 from Diane Dedert regarding the repeal of the pit bull ban
- 25 Email dated January 30, 2017 from Dave Wineman regarding the repeal of the pit bull ban
- 26 Email dated January 30, 2017 from Tracy Dedert regarding the repeal of the pit bull ban
- 27 Email dated January 30, 2017 from Andy Wilson regarding the repeal of the pit bull ban
- 28 Email dated January 31, 2017 from Ashley Rhodes regarding the repeal of the pit bull ban
- 29 Email dated January 31, 2017 from Frank Bougher regarding the repeal of the pit bull ban
- 30 Email dated February 1, 2017 from Maryrose Booher regarding the repeal of the pit bull ban
- 31 Email dated February 1, 2017 from Nichole McDonald regarding the repeal of the pit bull ban
- 32 Email dated February 1, 2017 from Judy Richter regarding the repeal of the pit bull ban
- 33 Email dated February 1, 2017 from Kevin McDonald regarding the repeal of the pit bull ban
- 34 Email dated February 2, 2017 from Jennifer Harutunian regarding the repeal of the pit bull ban
- 35 Email dated February 2, 2017 from Cynthiana Echele regarding the repeal of the pit bull ban
- 36 Email dated February 2, 2017 from Kristin Korte regarding the repeal of the pit bull ban
- 37 Email dated February 3, 2017 from Miriam Atlee regarding the repeal of the pit bull ban
- 38 Email dated February 2, 2017 from Jeff Cook regarding Plaza Madrid

VI. PUBLIC HEARINGS

16-09-026 Ward 3	Request to rezone for Lyons Properties, LLC d/b/a Dunkin Donuts the property located at 8115 N. Lindbergh from B-3 "Extensive Commercial District" to B-5 "Planned Commercial District" to allow for the construction of a new building. (Continued to this day on 9/27/16,10/24/16, 11/28/16, 1/9/16/23/17)	Tim Kaufmann
17-02-004 (Ward 9) Application Staff Rpt Plans	Request to issue an amendment to B-5 Ordinance No. 6868 to allow for a new sit-down carry-out restaurant with signage for the property located at 2180 N. Highway 67. (Planning and Zoning recommended approval on 1/17/17)	Michael Mueller

VII. OLD BUSINESS

A. SECOND READINGS

9255 Application Staff Rpt Plans	Ordinance to authorize an amendment to Special Use Permit No. 4830, as amended by Ordinance nos. 5071, 5255, and 5259 for the location of a ground sign in an R-4 Zoning District for the property located at 1001 Dunn Road.	2 nd reading Schildroth
9256 Application Staff Rpt Plans	Ordinance to authorize an amendment to Special Use Permit no. 7398 to allow for exterior alterations for the property located at 1261 Graham Road. (To be continued to the next Council meeting at the request of the petitioner)	2 nd Reading Schildroth

VIII. NEW BUSINESS

IX. BOARD APPOINTMENTS

X. REQUESTS

Ward 2 Application	Request for Donna Scholl to keep 3 hens located at 1485 Lindsay Lane. (Health Department recommended approval)	Donna Scholl
Ward 9 Application	Request to accept the application to transfer Special Use Permit 7716 from Tot Lots Learning Center to Florissant Kids Care Center LLC for the operation of a day care located at 2184 N. Waterford Drive.	Elizabeth Johnson

XI. RESOLUTIONS

993 Memo	A resolution authorizing the Mayor of the City of Florissant to make application under the Municipal Parks Grant for planning services at Manion Park for an inclusive playground.	Council as a whole
-------------	--	-----------------------

XII. BILLS FOR FIRST READING

9257	Ordinance to authorize an amendment to B-5 Ordinance No. 6868 to allow for a new sit-down carry-out restaurant with signage for the property located at 2180 N. Highway 67.	Siam
------	---	------

9258 Memo	Ordinance amending the general fund budget to reflect \$85,000 from asset forfeiture funds in escrow to forfeiture revenue account 01-4-34511 and to the forfeiture expenditure account 01-5-49-61000 for various police department expenditures.	Pagano
9259	Ordinance authorizing a transfer of Special Use Permit 7716 from Tot Lots Learning Center to Florissant Kids Care Center LLC for the operation of a day care located at 2184 N. Waterford Drive.	Siam
9260	Ordinance amending Title II Chapter 205 by deleting section 205.395 "Regulation Of Pit Bull Dogs"	Pagano, Caputa
9261	Ordinance amending Title II Chapter 205 by amending section 205.260 "Dangerous Animals".	Pagano, Caputa
9262 Memo	Ordinance amending revenue account no. 3490 "Grants and Reimbursements" in the amount of \$9,780 and appropriating the sum of \$9,780 from the General Revenue Fund to budget account no. 4921 "Uniforms" to purchase ballistic vests awarded through a local law enforcement block grant.	Pagano

XIII. MOTION TO MOVE THE FEBRUARY 27TH CITY COUNCIL MEETING TO TUESDAY, FEBRUARY 28TH.

XIV. COUNCIL ANNOUNCEMENTS

XV. MESSAGE FROM THE MAYOR

XVI. ADJOURNMENT

THIS AGENDA WAS POSTED AT THE FLORISSANT CITY HALL FEBRUARY 10, 2017 AT 12:00 PM ON THE BULLETIN BOARD OUTSIDE THE COUNCIL CHAMBERS. ANY ONE WISHING TO ATTEND THE COUNCIL MEETING WHO HAS SPECIAL NEEDS SHOULD CONTACT THE CITY CLERK'S OFFICE AT 839-7630 OR TDD 839-5142 BY NOON ON MONDAY, FEBRUARY 13, 2017.

1

CITY OF FLORISSANT

2



3
4
5
6

COUNCIL MINUTES

7
8

January 23, 2017

9
10

11 The Florissant City Council met in regular session at Florissant City Hall, 955 rue St. Francois
12 on Monday, January 23, 2017 at 7:30 p.m. with Council President Pagano presiding. The Chair asked
13 everyone in attendance to stand and join in the Pledge of Allegiance.

14 On Roll Call the following Councilmembers were present: Jones, Eagan, Caputa, Schildroth,
15 Henke, Pagano, Schmidt, Siam and Lee. Also present was Mayor Thomas P. Schneider, City Attorney
16 John Hessel and City Clerk Karen Goodwin. A quorum being present the Chair stated that the Council
17 meeting was in session for the transaction of business.

18 Councilman Henke moved to approve the Meeting Minutes and Executive Meeting Minutes of
19 1/9/17, seconded by Siam. Motion carried.

20 The Chair stated that the next item on the agenda was *Hearing from Citizens* and asked any
21 citizen who wished to speak to come forward.

22 Nathan Kinsey, 2452 Manthorne Ct, stated that a house had burned down behind his residence.
23 He stated that Public Works informed him that resolving the issue would take approximately 4 months.
24 It has been 15 months since the fire. He has called Public Works at least 3 more times and received no
25 response. A Police Officer inspecting the site informed him that they were waiting for a “volunteer
26 group” to clean it up. Mr. Kinsey did not think it was fair that he had to wait for a volunteer group to
27 clean the site before the issue was addressed.

28
29 Don Mills, 1560 Flordawn, stated that the BSL group has been attending the City Council
30 meeting for months, peacefully presenting facts and data and pleading their case. Why has there been
31 no respectful response from the Council? It is their responsibility as legislators to represent their
32 constituents and stop ignoring their requests.

33
34 Rosie Booher, 1823 Kingsford Dr, asked what the ramifications were if the animal control
35 officer or DNA tests mislabeled a dog. She asked the Council to repeal the BSL law.
36

37 Kim Ramatowski, 1865 Gardenia Dr, discussed various DNA testing used in identifying dogs'
38 breed history. She asked the City Council to please repeal the BSL.

39 Emily Hutton, 24 Silverdale Ct, stated that, after having planned on relocating to Florissant, she
40 decided on St. Charles because St. Charles had no law banning pit bull dogs.

41
42 Bonnie Boime, 1915 Mitchell Pl, President of the Animal Rights Team, stated that her office
43 had received numerous calls from Florissant residents regarding the BSL. It has a ripple negative effect
44 on the surrounding communities who then have to forest/adopt/shelter a larger number of stray pitbull
45 dogs. She agreed that it is very difficult to identify a pit dog without a DNA test and it was wrong to
46 make the residents pay for it. Florissant already has a comprehensive dangerous dog ordinance.

47
48 Karen Runk, 519 Redondo, stated that the BSL does not work and asked the Council to repeal
49 it.

50
51 Mike Cardenes, 2475 Stoney End Ct, shared information/data regarding the BSL organization
52 and their repeated efforts to have the BSL repealed. He thanked the Council for listening and asked
53 that they now take action to repeal the pit-bull law.

54
55 John Englemeyer, 1281 Graham Rd, thanked the BSL for all their efforts. Mr. Englemeyer
56 asked that after the election in April, that the Council members review the City Charter. He reviewed
57 certain sections and areas of concern regarding the Charter.

58
59 Lisa Andris, 350 Brackleigh, thanked the Council for their new rental licensing regulations. As
60 a realtor, over the last year, she has had 3 qualified younger families decline to buy a house in
61 Florissant because of the pitbull ban. From a practical, business perspective Florissant is "shooting
62 themselves in the foot" and should repeal their archaic BSL law.

63
64 Kelly Owens, 775 Gonzaga, stated that she owns a loving, registered pit bull dog which was
65 "grandfathered" in. She lived in Florissant before the ban was enacted and complied with all the
66 regulations. The dog is well trained, has never been a problem and is socialized with other animals and
67 people. She will be moving from the city if the ban is not removed.

68
69 The Chair stated that the next item on the agenda was *Communications*.

- 1 Email dated January 9, 2017 from Joe Arechederra stating his reasons for moving from Florissant.
- 2 Email dated January 9, 2017 from Connie Nolan requesting a repeal of the pit bull ban.
- 3 Email dated January 9, 2017 from Donna Besaw requesting a repeal of the pit bull ban.
- 4 Email dated January 10, 2017 from Donna Slemmer requesting the repeal of the pit bull ban.
- 5 Email dated January 10, 2017 from Carl Hughes requesting the repeal of the pit bull ban.
- 6 Email dated January 10, 2017 from Stefanie Skaggs requesting the pit bull ban be repealed.
- 7 Email dated January 10, 2017 from Andrea Castleberry requesting the pit bull ban be repealed.
- 8 Email dated January 10, 2017 from Megan Leigh requesting the pit bull ban be repealed.
- 9 Email dated January 10, 2017 from Jacob Taylor requesting the repeal of the pit bull ban.
- 10 Email dated January 10, 2017 from Wendy Murtagh requesting the repeal of the pit bull ban.
- 11 Email dated January 10, 2017 from Katherine Muich requesting the repeal of the pit bull ban.
- 12 Email dated January 10, 2017 from Anthony Zurbruggen requesting the repeal of the pit bull ban.
- 13 Email dated January 10, 2017 from Lacey Knox requesting the repeal of the pit bull ban.

- 14 Email dated January 10, 2017 from Amanda Fillet requesting the repeal of the pit bull ban.
- 15 Email dated January 11, 2017 from Sandra Link requesting the repeal of the pit bull ban.
- 16 Email dated January 11, 2017 from Jordan Oxford requesting the repeal of the pit bull ban.
- 17 Email dated January 11, 2017 from Cheryl Genail requesting the repeal of the pit bull ban.
- 18 Email dated January 11, 2017 from Courtney Douty requesting the repeal of the pit bull ban.
- 19 Email dated January 12, 2017 from Missouri K9 Friends requesting the pit bull ban be repealed.
- 20 Email dated January 15, 2017 from Jessa Stone requesting the pit bull ban be repealed.
- 21 Email dated January 15, 2017 from Cheryl Wittenauer requesting the repeal of the pit bull ban.
- 22 Email dated January 14, 2017 from Robin Brown requesting the repeal of the pit bull ban.
- 23 Email dated January 13, 2017 from Frank Bougher requesting the repeal of the pit bull ban.
- 24 Email dated January 13, 2017 from Samantha Scarfino requesting the repeal of the pit bull ban.
- 25 Email dated January 13, 2017 from Gail Scarfino requesting the repeal of the pit bull ban.
- 26 Email dated January 12, 2017 from Emma Rehfeld requesting the repeal of the pit bull ban.
- 27 Email dated January 18, 2017 from The Staff of Slem's Pet Care Service requesting the repeal of
the pit bull ban
- 28 Email dated January 18, 2017 from Michael Cardenas-Salas requesting the repeal of the pit bull
ban.
- 29 Email dated January 18, 2017 from Michelle Yancy requesting the repeal of the pit bull ban.
- 30 Email dated January 18, 2017 from Kristin Korte requesting the repeal of the pit bull ban.
- 31 Email dated January 19, 2017 from Heather Dye requesting the repeal of the pit bull ban.
- 32 Email dated January 19, 2017 from Donald Allen requesting the repeal of the pit bull ban.
- 33 Email dated January 19, 2017 from Andrea Purvis requesting the repeal of the pit bull ban.

70

71 The next item on the Agenda was Public Hearings.

72 The City Clerk reported that Public Hearing #16-09-026 to be held this night on a request to
73 rezone for Lyons Properties, LLC d/b/a Dunkin Donuts the property located at 8115 N. Lindbergh from
74 B-3 "Extensive Commercial District" to B-5 "Planned Commercial District" to allow for the
75 construction of a new building had been advertised in substantially the same form as appears in the
76 foregoing publication and by posting the property. The Chair declared the Public Hearing to be open
77 and invited those who wished to be heard to come forward.

78 Chairman Pagano stated that the petitioner had requested a continuance. Being no citizens who
79 wished to speak, Councilman Eagan moved to postpone P.H. #16-09-026 to 2/13/2017, seconded by
80 Caputa. Motion carried.

81 The City Clerk reported that Public Hearing #17-01-001 to be held this night on a request to
82 authorize an amendment to Special Use Permit No. 4830, as amended by Ordinance Nos. 5071, 5255,
83 and 5259 for the location of a ground sign in an R-4 Zoning District for the property located at 1001
84 Dunn Rd. had been advertised in substantially the same form as appears in the foregoing publication

85 and by posting the property. The Chair declared the Public Hearing to be open and invited those who
86 wished to be heard to come forward.

87
88 John Boain, petitioner, stated that he would like to place his sign closer to the street so that it
89 would be more visible to his patients. His patients often miss the entrance to the site, turn around on
90 Dunn Rd, and reenter the lot. This creates a dangerous traffic flow on Dunn Road at the location where
91 cars merge onto Highway 270.

92 Councilman Schildroth agreed that a first time patient might easily pass up the entrance to the
93 lot and that more visibility was needed. He appreciated that Dr. Boain considered the various options
94 presented by Planning & Zoning. Mayor Schneider thanked the petitioner and his father for operating
95 their dental practice in Florissant for many years.

96 The Chair asked if there were any citizens who would like to speak on said public hearing.
97 Being no citizens who wished to speak, Councilman Schildroth moved to close P.H. #17-01-001
98 seconded by Caputa. Motion carried.

99 The City Clerk reported that Public Hearing #17-01-002 to be held this night on a request to
100 issue an amendment to B-5 Ordinance No. 8235 to allow for exterior modifications to a new self-
101 storage, truck and trailer facility for the property located at 1350 N Hwy 67 had been advertised in
102 substantially the same form as appears in the foregoing publication and by posting the property. The
103 Chair declared that, at the request of the petitioner, the request had been withdrawn.

104 The City Clerk reported that Public Hearing #17-01-003 to be held this night on a request
105 authorize an amendment to Special Use Permit No. 7398 to allow for exterior modifications for exterior
106 alterations for the property located at 1261 Graham Road had been advertised in substantially the same
107 form as appears in the foregoing publication and by posting the property. The Chair declared the
108 Public Hearing to be open and invited those who wished to be heard to come forward.

109 Richard Avery, petitioner, stated that this site was a Starbucks coffee shop. They are asking to
110 complete a remodel of the exterior and interior of the building. There are areas existing on the current
111 Starbucks store that are painted wood and brick. They would like to paint the brick a slightly different
112 color, of which he had samples, and add screening of the mechanical equipment to the roof line of the
113 building. Also there is a sign package included which complies with Florissant's sign code. He
114 displayed samples of the siding which would replace the wood siding and also covering some of the
115 existing brick in order to obtain a more uniform, crisp appearance.

116 Although Councilman Schmidt appreciated the remodeling, he asked if Starbucks could provide
117 coloring renderings so that the Council could see what it would look like. Mr. Avery stated that he
118 would send the color renderings before the next meeting.

119 Councilman Schildroth stated that this Starbucks on Graham Rd was one of the three remaining
120 open in the area and it is always a very busy location. They will resurface the parking lot, screen the
121 HVAC equipment, replace the panels and repair the bricks. He is happy with the proposed
122 improvements.

123 The Chair asked if there were any citizens who would like to speak on said public hearing.
124 Being no citizens who wished to speak, Councilman Schildroth moved to close P.H. #17-01-003
125 seconded by Henke. Motion carried.

126 Councilman Eagan moved that Bill No. 9250 An Ordinance to rezone for Regions Bank the
127 property located at 100 N Hwy 67 to re-establish the existing B-5 Planned Commercial District to allow
128 for the construction of a bank branch with drive-thru facility be read for a second time, seconded by
129 Jones. Motion carried and Bill No. 9250 was read for a second time. Councilman Eagan moved that
130 Bill No. 9250 be read for a third time, seconded by Schmidt. Motion carried and Bill No. 9250 was
131 read for a third and final time and placed upon its passage.

132 Before the final vote all interested persons were given an opportunity to be heard. On roll call
133 the Council voted: Jones yes, Eagan yes, Caputa yes, Schildroth yes, Henke yes, Pagano yes, Schmidt
134 yes, Siam yes and Lee yes. Whereupon the Chair declared Bill No. 9250 to have passed and said Bill
135 became Ordinance No. 8294.

136 Councilman Henke moved to reappoint Jack Folkers, 1505 Swallow, to the Personnel
137 Commission as a member from Ward 1 for a term expiring on 1/23/2021, seconded by Eagan. Motion
138 carried.

139 Councilman Jones moved to reappoint David Hill, 75 Francisca, to the Board of Adjustment as
140 a member from Ward 2 for a term expiring on 1/13/2022, seconded by Lee. Motion carried.

141 Councilwoman Pagano moved to appoint Robert Nelke, 5 Fountain Ct., to the Planning &
142 Zoning Commission as a member from Ward 7 for a term expiring on 1/24/2021, seconded by
143 Schildroth. Motion carried.

144 Councilman Henke moved to accept the Mayor's reappointment of Fred Schaljo, 1460
145 Pepperhill, to the Youth Advisory Commission as an adult member from Ward 6 for a term expiring on
146 1/22/2022, seconded by Eagan. Motion carried.

147 Councilman Schildroth introduced Bill No. 9255 An Ordinance to authorize an amendment to
148 Special Use Permit No. 4830, as amended by Ordinance Nos. 5071, 5255 and 5259 for the location of
149 a ground sign in an R-4 Zoning District for the property located at 1001 Dunn Road and said Bill was
150 read for the first time by title only.

151 Councilman Schildroth introduced Bill No. 9256 An Ordinance to authorize an amendment to
152 Special Use Permit No. 7398 to allow for exterior alternations for the property located at 1261 Graham
153 Road and said Bill was read for the first time by title only.

154 The next item on the Agenda was Council Announcements.

155 Councilman Henke thanked the city staff for their preparation for the recent ice storm. He also
156 thanked the residents who stayed at home and off the streets.

157 Councilman Caputa encouraged residents to secure their firearms and not leave them in their
158 vehicles. He also asked residents to leave their porch lights on at night to deter crime. MSD will be
159 working at Humes at Patterson Lane. Work segments will be done in 24 hours increments.

160 Councilman Eagan announced that Race to the Shrine is held in October in Florissant. The St.
161 Ferdinand Charity BQ and Basketball Tournament will begin in March and will benefit Hazelwood
162 Officer Greg Tudor.

163 Councilman Jones encouraged all residents to contribute/donate to TEAM. He thanked Carole
164 Webb and his Neighborhood Watch team for all the work that they do. He reminded residents that the
165 Shackelford Road Project will take approximately two years to complete. He asked drivers to take their
166 time when driving through that area.

167 Councilman Pagano announced that the Council will be having a work session on Monday
168 January 30 at 6:30 in Council Chambers and residents are invited to attend.

169 The next item on the Agenda was Mayor Announcements.

170 Mayor Schneider congratulated Gary Gaydos on being honored with the “Theatre in Arts
171 Award” presented by the Missouri Fine Arts Council. Mr. Gaydos was the Theatre Director of the
172 Florissant Theatre for 38 years until his recent retirement. The Parks and Recreation Department
173 hosted a huge youth hockey tournament about two weeks ago. There will be a free skate on January
174 16th and Feb 20th. There will be a snowman building contest through Feb 28.

175 The next City Council Meeting is scheduled for Monday, February 13, 2017 at 7:30 pm.
176 Councilman Henke moved to adjourn the meeting, seconded by Schmidt. Motion carried. The
177 meeting was adjourned at 8:29 p.m.

178
179
180
181
182
183
184
185
186

The following Bills were signed by the Mayor:

Bill No. 9250 Ord. 8294

Karen Goodwin, City Clerk

To the city council and mayor of Florissant,

I have worked in the animal related field for 14 years now. I was a kennel manager, a vet technician, a dog trainer, I've worked in animal rescue and foster, worked at an animal shelter, and most importantly I was an animal control officer and animal cruelty investigator in Columbia and Boone County Missouri. As an ACO I enforced all animal laws, including but not limited to vicious dog laws. I can tell you from experience that a good vicious dog law is much more efficient than any breed specific laws. You currently have a good, breed neutral vicious dog law on the books. Deeming dogs vicious by behavior, instead of breed, is much safer for the public. The CDC, AKC, NACA, and even the American Barr Association, along with many other major groups, have stated publicly that they stand against breed specific laws. They do not protect the public in any way. And instead they hurt revenue as people refuse to travel through cities with breed bans. Breed specific laws harm responsible owners and kill innocent dogs.

Not one credible source has proven breed specific laws to work. They actually have a tendency to compromise rather than enhance public safety. When your resources as a field officer are used to enforce breed bans or restrictions, your focus gets redirected from where it should be. And that is on keeping the public safe. Your focus gets taken away from effective enforcement of laws that have the best chances of making the city safer and instead it gets focused on laws that have been proven inefficient, and that have been proven to hurt the city. Currently the Florissant Bully Alliance has been getting complaints about a vicious dog in Florissant. This dog is a pit bull and it's being ignored because animal control claims "it may be grandfathered in to the ban." I sincerely hope I don't need to explain why that's ridiculous. Your officials are enforcing the ban and the ban alone. This is why your dog bites have skyrocketed since the ban was enacted. I'm shocked that none of you have proposed a repeal at this point based on the actual facts, numbers, and information provided.

These laws hurt the city because they are costly, and difficult to enforce. Breed-specific laws also encourage irresponsible dog ownership. As certain breeds are regulated, people who want to get a dog and train it to be dangerous are likely to turn to just other, unregulated breeds. In other words, bad owners will always be bad owners, despite what breed they own. You also run into the issue of, again, criminals and irresponsible owners, finding the thought of owning an "illegal" breed desirable. According to the ASPCA the rise of pit bull ownership among gang members in the late 1980s coincided with the first round of breed-specific legislation.

In my line of work, I did work with quite a few vicious dogs of all breeds. And I can tell you that any vicious dog can and will hurt you. And any vicious large sized dog is extremely dangerous. I have had my life and my body put in danger to protect the public from vicious dogs of various breeds. And it is a scary situation to be put in. However, I take public safety very seriously, and I hope you will too, by repealing your breed discriminatory law and letting your officials focus more resources on a breed neutral dangerous dog ordinance, deeming dogs dangerous based on behavior not breed. Recently, MO cities all over are repealing laws like this. Keeping this law in place is putting your city at risk for litigation as well as hindering public safety. Please do not punish responsible dog owners, and address the real problem at hand. Irresponsible pet owners. Make Florissant a safer place to live.

Ideally to lower dog bites and dog attacks, you need a good, breed neutral dangerous dog law. You need a good animal control department that is available for your jurisdiction, whether that be the city itself or contracted with the county. You need to encourage responsible ownership. Free spay and neuter vouchers, low cost vaccination clinics, education programs in schools on animal welfare are just some examples. Another popular trend happening in animal law currently is anti-tether laws. A lot of the vicious dogs I have come across were tethered on chains or cables for long periods of time. I would love to offer my expertise and assistance to the beautiful city of Florissant. My family that resides there currently doesn't feel protected from vicious dogs. My friends are reaching out for help because the city is allowing vicious dogs to roam the streets because of this ban.

Please feel free to contact me if you have any questions. When getting information to make this decision, please look at reliable sources and credible research. Talk to the experts. That will point you in the right direction. Websites like dogsbite get their "statistics" by searching google for news articles. It is extremely inaccurate and biased.

I have dealt with some scary cases involving vicious dogs and breed specific laws increase dog attacks. In Florissant your dog bites have gone up 115% since the ban was enacted. I hope you understand the severity of that jump. It's similar to gun laws. If you ban guns, it only punishes the good guys. If you ban pit bulls, you run into a lot of issues, risk litigation, and you're only punishing responsible owners. Breed identification is a huge issue and costs a lot of money to enforce. And you will be punishing responsible owners like myself, when you should be focused on punishing irresponsible owners. I also don't appreciate my St Louis County tax dollars paying for you to kill innocent dogs. The County only had information starting from November 2011 and forward when we filed our sunshine law request. However, from November 2011 to August of this year, the total number of pit bull and pit bull type dogs transferred to St. Louis County from Florissant was 201 dogs. Of those 201, 164 dogs were euthanized. The cost to St. Louis County taxpayers to euthanize these 164 dogs was \$6978.20.

In less than 5 years, Florissant is responsible for the killing of 164 family members because of the breed ban and it cost myself along with every other St. Louis County taxpayer close to \$7000.00 to kill them.

Please find a resolution to this.

Signed, Mandy Ryan.

Executive Director of STOP Breed Specific Legislation in Missouri

My address is 1524 Maple Ln in Ellisville and I would like my email included on the next city council agenda. Please reply so I know my email was received.

Karen Goodwin

From: Gail Scarfino <gscarfino@sbcglobal.net>
Sent: Monday, January 23, 2017 11:10 PM
To: Karen Goodwin
Subject: BSL

To the city council as a whole.

Hi, my name is Gail Scarfino. I am a St. Louis County resident, my address is 4012 Shackelford Rd, Florissant, MO 63034.

I am writing once again in hopes that the Breed Specific Legislation in Florissant will be repealed. Please include my email on the next city council meeting agenda and please reply verifying that my email has been received and will be included on the agenda.

Below are the professional opinions of just a few organizations.

American Veterinary Medical Association (AVMA)

"The American Veterinary Medical Association supports dangerous animal legislation by state, county, or municipal governments provided that legislation does not refer to specific breeds or classes of animals. This legislation should be directed at fostering safety and protection of the general public from animals classified as dangerous."

(<https://www.avma.org/KB/Policies/Pages/Dangerous-Animal-Legislation.aspx>)

American Veterinary Medical Association PRIT (AVMA PLIT)

"The AVMA does not support the adoption of breed specific bans by insurers and does support education programs to teach the public proper safety precautions when dealing with strange or dangerous dogs."

(www.avmaplit.com)

American Veterinary Society

American Veterinary Society of Animal Behavior (AVSAB)

"The AVSAB's position is that such legislation—often called breed-specific legislation (BSL)—is ineffective, and can lead to a false sense of community safety as well as welfare concerns for dogs identified (often incorrectly) as \belonging to specific breeds. The importance of the reduction of dog bites is critical; however, the AVSAB's view is that matching pet dogs to appropriate households,adequate early socialization and appropriate training, and owner and community education are most effective in preventing dog bites. Therefore, the AVSAB does support appropriate legislation regarding dangerous dogs, provided that it is education based and not breed specific."

Karen Goodwin

From: Vickie Rolfes <vrolfes@yahoo.com>
Sent: Monday, January 23, 2017 10:14 PM
To: Karen Goodwin
Subject: Dog breed bans

Florissant city council members.

I am a Florissant citizen for the last 23 years. I am also a dog lover, and am asking that you vote to lift the ban on potbulls in florissant. I would like this email added to the agenda at the next council meeting. Thank you for your time.

Vickie Rolfes
700 mark twain
Florissant, Mo 63031

Sent from Yahoo Mail on Android

Karen Goodwin

From: acn8119 <acn8119@yahoo.com>
Sent: Monday, January 23, 2017 9:20 PM
To: Karen Goodwin
Subject: To

To city council as a whole:

Im writing to say that as a florissant resident I would like the pit bull ban repealed. Please include this email on the next city counsel agenda. Please reply verifying my email was received and will be included on the agenda

Thank You,
Amy Newton
450 Naomi Ave
Florissant, Mo 63031

Sent from my Boost Mobile Phone.

Karen Goodwin

From: Erin Berghold <eberghold@sbcglobal.net>
Sent: Monday, January 23, 2017 9:07 PM
To: Karen Goodwin
Subject: To the city council as a whole / Repeal pit bull ban

I respectfully ask the city council as a whole to REPEAL THE PIT BULL BAN. I fully believe that these dogs as a whole should not be punished for the actions of a few that resulted in improper training by the owners. Ban bad owners not innocent dogs. Thank you.

Please include my email in the next city Council meeting agenda. I'd like a reply confirming receipt of my email and that it will be included in the meeting agenda.

Erin Berghold
755 Charvel dr.
Florissant MO 63031

Erin Berghold

Sent via the Samsung GALAXY S® 5, an AT&T 4G LTE smartphone

Karen Goodwin

From: Heather Dye <heather_dye@rocketmail.com>
Sent: Monday, January 23, 2017 8:50 PM
To: Karen Goodwin
Subject: BSL

Dear city council members,

I am a St.Louis County resident my address is 6709 Village Square Dr Hazelwood, MO 63042. My name is Heather Dye and I would like to ask that you ban breed specific legislation. Please reply that this email was received, and please include my email on the next meeting agenda. Thank you for your time.

Sincerely,
Heather Dye

Sent from Yahoo Mail on Android

Karen Goodwin

From: Cat Schleicher <calamity_cat103@yahoo.com>
Sent: Monday, January 23, 2017 3:20 PM
To: Karen Goodwin
Subject: STOP BSL

To the Members of City Council,

I am writing to you to voice my outrage over the ban of specific dog breeds in St. Louis counties, including Florissant. I am outraged because I know that we can do better than to ban and (inevitably) euthanize "man's best friend." It is our duty to care for, and protect animals, not to kill and vilify them. There is no evidence linking specific breeds to aggression. Not to mention, a ban on specific breeds is so problematic, as mixed breed dogs can be confused for a number of breeds.

We should also consider that breed specific legislation costs tax payer money, and that money is spent to murder dogs. That same money would be better spent rehabilitating dogs. As an employee of an animal shelter, I would rather rehabilitate an aggressive dog than put down a good one, which is what happens with BSL. Good people don't like putting down dogs. Don't make it someone's job to murder pit bulls, I beg of you.

Finally, there are people that won't move to Florissant, and other St. Louis counties, because of the ban on their dog. Which means we are also banning potential workers, citizens, and tax payers. Those people instead, will live somewhere with laws that don't harm dogs (and their people).

I ask that you reconsider this archaic ban; for dogs, for people, and for the betterment of St. Louis. Let us be a city of life and joy, for people and pets. Not a place where dogs go to die.

Thank you,
Brittany Schleicher

Sent from my iPhone

Karen Goodwin

From: Castleberry, Andrea <Andrea.Castleberry@marketstrategies.com>
Sent: Tuesday, January 24, 2017 1:17 PM
To: Karen Goodwin
Subject: PLEASE END BSL

Members of the City Council:

We again ask that you consider lifting the pit bull ban. This is not justice; this is discrimination.

Thank you for your time.

Andrea Castleberry
5414 Blow Street
Saint Louis, MO 63109

Andrea Castleberry
Global Sourcing Manager | Market Strategies International
D 734.779.6852 M 314.650.7738
andrea.castleberry@marketstrategies.com

Connect with us:
marketstrategies.com | freshmr.com
[Twitter](#) | [Facebook](#) | [LinkedIn](#)

ISO 20252 Certified

Karen Goodwin

From: Laura Wichlinski <lwichlinski@icloud.com>
Sent: Tuesday, January 24, 2017 3:55 PM
To: Karen Goodwin
Subject: BSL PitBull Ban

Members of the City Council... We again ask, no, we implore you to lift the ban on pit bulls. This is not justice. This is discrimination.

As being an owner of a Pit Bull, I'd be devastated if someone came to take away Gunner (yes our household supports the Second Amendment). He has been nothing short of amazing, sweet, and great with children. One bad dog doesn't make the whole breed vicious and aggressive. Gunner is my best friend and right hand man, and I don't think you'd be ok with a stranger showing up at your door and basically kidnapping a member of your family. I'm unable to have children, so he is my child and whole world. Please think about what your doing to many innocent dogs and families.

Thank you for your time.

Laura Wichlinski RN, BSN, NASM-CPT, PN-1, CES, PES lwichlinski@yahoo.com
314-660-9323

Karen Goodwin

From: Mindy Boyer <mbgrooming@gmail.com>
Sent: Tuesday, January 24, 2017 4:17 PM
To: Karen Goodwin
Subject: Pitbull Ban repealed

Dear Councilmembers,

I would like to request repeal of the ban on pit bull breeds by the city of Florissant. Please focus on the breed neutral aggressive dog ordinance. Thank you!

For Council and for Inclusion in Communications Portion of the February 13th Agenda.

Mindy Boyer
Ward 6
1160 Pamela Dr Florissant, MO 63031

Karen Goodwin

From: cnolanloveslife <cnolanloveslife@gmail.com>
Sent: Tuesday, January 24, 2017 7:18 PM
To: Karen Goodwin
Subject: BSL

To the entire Florissant city council,

I am writing to ask that you repeal the pit bull ban in Florissant.

Additionally, Ms. Goodwin, if you will, please add this email to the communications portion of the agenda.

Thank you for your time!

Connie Nolan
170 Ruth Drive
Florissant Mo 63031
Tim Jones-Ward 2

Sent on a Sprint Samsung Galaxy Note® II

Karen Goodwin

From: Sandra L. <sandralink42@gmail.com>
Sent: Tuesday, January 24, 2017 6:29 PM
To: Karen Goodwin
Subject: To the city council as a whole.

I am writing to you once again, to state to you that as a current constituent and resident of Florissant, I want the breed specific legislation, particularly that specific to Pitbulls, repealed.

The aggressive dog legislation on the books is more than sufficient to keep our residents **safe from dogs whom are actually dangerous** when appropriately implemented.

I, as well as many other residents of both Florissant and St. Louis county, **do NOT support this ban.**

Stop wasting our city's and county's resources on this unsuccessful and **illegal ban.**

Do include my email regarding the ban on the next city council agenda. I want this email to be read by and to the council members as I am unable to attend this meeting.

Sandra Link 685 Madison Ln. Florissant Mo. 63031

Karen Goodwin

From: Cheryl Entwistle
Sent: Wednesday, January 25, 2017 8:55 AM
To: Karen Goodwin
Subject: FW: Save tax dollars and pets: Repeal the breed discriminatory law

Hi Karen,
Please add to correspondence per the Mayor.
Thanks,
Cheryl

-----Original Message-----

From: Mayor Schneider
Sent: Tuesday, January 24, 2017 8:06 PM
To: Cheryl Entwistle
Subject: RE: Save tax dollars and pets: Repeal the breed discriminatory law

Send to Karen to add to correspondence and let Ms. Keesling know that we forwarded her message to the City Council who have the legislative authority to modify our city ordinances.

-----Original Message-----

From: Cheryl Entwistle
Sent: Tuesday, January 24, 2017 8:38 AM
To: Mayor Schneider
Subject: FW: Save tax dollars and pets: Repeal the breed discriminatory law

Hi Mayor,
Please see email below.
Thanks,
Cheryl

-----Original Message-----

From: Best Friends Animal Society [<mailto:Legislative@bestfriends.org>] On Behalf Of Becky Keesling
Sent: Tuesday, January 24, 2017 6:02 AM
To: Cheryl Entwistle
Subject: Save tax dollars and pets: Repeal the breed discriminatory law

Jan 24, 2017

Mayor Thomas Schneider
Florissant, MO

Dear Mayor Schneider,

We all want safe and humane communities. As a Florissant resident, I ask that you repeal the breed-discriminatory ordinance targeting alleged "pit bull" terriers. The old ordinance is not only ineffective, but it is expensive to enforce and violates the property rights of responsible pet owners.

The city council should listen to its caring residents who attend city council meetings each month and act to repeal the ban. The city needs to move onto other important matters. Wentzville, Town & Country, Clayton and Manchester -- like numerous Missouri cities -- have all repealed "pit bull" laws. Florissant should follow their lead.

It is clear that breed discrimination goes against the tenets of community policing. How can people trust government officials if their well-behaved pets are seized for no reason? Do we really want to be known as a community that makes citizens get rid of their innocent pet dogs? The focus of any dangerous dog law should be on the behavior of the owner and the behavior of the dog.

Florissant should not embrace the discriminatory policies of Ferguson that include an ordinance targeting pit bull terriers. Our community is better than that. We should prohibit reckless owners from owning pets (as the city of Skokie, Illinois, has done), rather than penalize responsible pet owners for the alleged breed of their dogs.

In America, responsible dog owners who follow safety rules should be able to own whatever breed of dog they choose. It's that simple.

Thank you for your efforts to repeal the breed discriminatory law and make Florissant a community where people with pets want to live.

Sincerely,

Ms. Becky Keesling
1235 Saint Mark Dr
Florissant, MO 63031-7709
(314) 650-6607
beekeesling@yahoo.com

Karen Goodwin

From: Debbie Causevic <dcausevic@yahoo.com>
Sent: Wednesday, January 25, 2017 2:48 PM
To: Karen Goodwin
Subject: Request to repeal pit bull ban

Members of the City Council:

This email is in request to repeal the bit bull ban currently in place in Florissant. Regardless of a dog's breed, all dogs are capable of being loving pets. Euthanizing someone's pet because they resemble a banned breed is horrific. Instead of banning a breed of animal, Florissant should invest the funds being used against pit bulls into education promoting responsible pet ownership. The incidents of dog attacks that the council fears arise when pit bulls (or any dog) is trained to fight or are grossly mistreated.

70 - 80 million dogs live peacefully in homes throughout the United States. Several million of these are pit bulls living in loving homes.

Thank you for your consideration.

Debbie Causevic
471 Mission Bay Dr.
Wildwood, MO 63040

Karen Goodwin

From: Melissa Jeffery <melissaljeffery@gmail.com>
Sent: Wednesday, January 25, 2017 1:35 PM
To: Karen Goodwin
Subject: Re: FW: Attention Florissant City Council

Thank you - my address is:
1275 Saint Anthony Lane
Florissant, MO 63033

On Wed, Jan 25, 2017 at 1:19 PM, Karen Goodwin <kgoodwin@florissantmo.com> wrote:

Hello Melissa, Please include your address for the record so your email can be included with communications on the agenda.

Thank you,
Karen

From: Kim Emerson
Sent: Wednesday, January 25, 2017 1:18 PM
To: Karen Goodwin
Subject: FW: Attention Florissant City Council

From: Melissa Jeffery [<mailto:melissaljeffery@gmail.com>]
Sent: Wednesday, January 25, 2017 10:54 AM
To: Kim Emerson
Subject: Attention Florissant City Council

Hello,

I am writing to request the breed specific dog ban in the city of Florissant be repealed. Dogs are not aggressive because of their breeds, they are aggressive when they are trained to be so. Please consider this repeal seriously.

I see emails, citizens in person, letters, etc. brought up over and over again in the Council meeting minutes and would like an update to the consideration of repealing this ban.

I will continue to push for this effort.

Thank you,

Melissa Jeffery

Florissant Resident, Ward 8

--

Melissa Jeffery
1275 Saint Anthony Lane
Florissant, MO 63033

Karen Goodwin

From: Tamara Vastine <tamaravastine@yahoo.com>
Sent: Wednesday, January 25, 2017 11:43 AM
To: Karen Goodwin
Subject: Pit bull Ban

Dear city council members,

I would like you to reconsider the ban on pitbulls I am sking this thru email since I can't be at the council meeting myself

Please add this to the communications portion of the agenda for the next meeting of 2/13

Thanks for letting me speak
Tamara Vastine
2635 Cheshire dr
Florissant Mo 63033

Karen Goodwin

From: Angela Schaefer <adschaefer19@gmail.com>
Sent: Wednesday, January 25, 2017 1:26 PM
To: Karen Goodwin
Subject: To the Florissant City Council as a Whole

Dear Council Members,

I grew up in Florissant. I lived on 180 St. Madeline and 1944 Night Drive. Many of my family members and friends live in Florissant. In the spring of 2016 I was in a position to move my family to a new home but unfortunately Florissant, MO did not welcome me back. I have dogs who are "pit bull" mixes and therefore could not move to Florissant. Instead, I moved to Wentzville, MO, a municipality that has repealed their ban on pit bull type breeds.

The ban on pit bull breeds is discriminatory and does not address the issue of aggressive dogs. My "pit bulls" go to doggy daycare on a regular basis, have gone through extensive training, and have earned their certifications as "Canine Good Citizens" through the American Kennel Club. They love children and other dogs.

I am the VP of Human Resources for a leading insurance provider. I have earned a Bachelor's Degree, Master's Degree, and several professional certifications. I am a member of the Saint Louis Zoo Association Board of Directors, and the Board of Directors for Gateway Pet Guardians. I am a former Big Sister for Big Brothers Big Sisters of Eastern MO and I donate and volunteer my time regularly to a variety of philanthropic endeavors focusing on children and animal welfare. I am a pit-bull guardian and advocate. I mention this information not to be boastful but to alert you to the citizens you are discriminating against and preventing from moving into Florissant.

I would like to request the repeal of the ban on pit bull breeds by the city of Florissant. Please focus on a breed neutral aggressive dog ordinance. Thank you!

For Council and for Inclusion in Communications Portion of the February 13th Agenda.

Angie Schaefer
2 Robin Court
Wentzville, MO 63385

Sent from my iPad

Karen Goodwin

From: donna@slemspetcare.com
Sent: Wednesday, January 25, 2017 10:59 PM
To: Karen Goodwin
Subject: Repeal BSL

Dear Florissant City Council,

We at Slem's Pet Care respectfully ask that your city repeal BSL in your city. We have over 100 clients in your city that also ask that the ban is repealed. We would like to service more of your residents. Our tax dollars are being spent on a wasteful and inhumane action because of this ban in your city.

Please add our email to your meeting agenda.

Respectfully,
The Staff of Slem's Pet Care Service
2612 Poe Ave St. Louis, Mo. 63114
Michelle Stokes 63114
Brandy Henderson 63135
Cindy Basham 63114
Donna Slemmer 63114
Lisa Andris 63135
Miriam Atlee 63114
Cindy Fischer 63109

Karen Goodwin

From: Carl Hughes <chughes_1967@yahoo.com>
Sent: Thursday, January 26, 2017 4:33 AM
To: Karen Goodwin
Subject: Repeal BSL

Dear Members of the City
Council,
I'd like the council to repeal the Pit Bull Ban.
Stop using my tax money to euthanize your dogs.
Please include my email to the council meeting agenda.

Thank you,
Carl Hughes
2615 Roseland
Terrace
St. Louis, Mo 63143
314-366-2848

Karen Goodwin

From: Carl Hughes <chughes_1967@yahoo.com>
Sent: Wednesday, January 25, 2017 10:58 PM
To: Karen Goodwin
Subject: Repeal BSL

Dear Members of the City
Council,
I'd like the council to repeal the Pit Bull Ban.
Stop using my tax money to euthanize your dogs.
Please include my email to the council meeting agenda.

Thank you,
Carl Hughes
2615 Roseland
Terrace
St. Louis, Mo 63143
314-366-2848

Karen Goodwin

From: Donna <dslem3@yahoo.com>
Sent: Wednesday, January 25, 2017 10:54 PM
To: Karen Goodwin
Subject: Request REPEAL of BSL

Dear Members of the Florissant City Council,

I'd like to make known that I would like the Pit Bull Ban repealed.
Please include my email to the council meeting agenda.

Thank you.
Donna Slemmer
2612 Poe Ave
St. Louis, Mo
63114

Karen Goodwin

From: Donna Slem <oneforthemoney2@yahoo.com>
Sent: Thursday, January 26, 2017 10:18 PM
To: Karen Goodwin
Subject: Repeal BSL

To the Florissant City Council Respectively,

I have noticed the Pit Bull group at every meeting and am wondering why you all just ignore them? From the videos I have seen on your website, they have shown you proof that the ban doesn't work. What are you waiting for?
REPEAL IT ALREADY!!

I would like to have my email acknowledged during the communications section of the meeting.

Thank you,
Shawna Walker
St. Louis, Mo
63031

Karen Goodwin

From: cheryl genail <cgenail@hotmail.com>
Sent: Thursday, January 26, 2017 12:07 PM
To: Karen Goodwin
Subject: To the City Council as a whole

I am a Florissant resident and I am requesting repeal of the breed specific ban! The ban is wrong and unfair.

Please include my email on the next city council meeting agenda. I'd like a reply verifying that my email has been received and it will be included on the next agenda.

Thank you,

Cheryl Genail
2000 Thrush Dr.
Florissant, MO 63033

Karen Goodwin

From: Gail <howell.gail01@gmail.com>
Sent: Monday, January 30, 2017 8:17 AM
To: Karen Goodwin
Subject: Stop BSL Members of the City Council

Please stop taking these beautiful babies from their homes. It is not the breed it is owners that are not being responsible. Thanks.

Please add my email to the meeting agenda.

Gail Howell
4725 Jones Bridge Woods Drive
Alpharetta, GA 30022

Sent from my iPad

Karen Goodwin

From: Diane <ddert1@aol.com>
Sent: Monday, January 30, 2017 8:11 AM
To: Karen Goodwin
Subject: Repeal the ban on pit bulls

Members of the City Council

I respectfully ask that the ban on pit bulls (BSL) be ended. To banish a breed based on the actions of human "owners" is so wrong. Further, I request my email be added to the meeting agenda. Thank you

Diane C. Dedert
10119 Stephens Pl
St Ann, MO 63074
314 423 4591

Karen Goodwin

From: Donna Slem <oneforthemoney2@yahoo.com>
Sent: Monday, January 30, 2017 12:01 AM
To: Karen Goodwin
Subject: STOP BSL

Members of the Florissant City Council,

Listen to your residents and repeal this ban like all the other cities are doing!

It's ok to admit you were wrong!

The facts prove this ban does not work!

APRIL will be here before you know it and people are NOT happy!

Please add my email to the meeting agenda.

Thank you.

Dave Wineman
12763 New Halls Ferry Rd
Florissant, 63033

Karen Goodwin

From: Tracy <td3738@yahoo.com>
Sent: Monday, January 30, 2017 10:07 AM
To: Karen Goodwin
Subject: Members of the City Council

Please add my email to the meeting agenda. I ask that you please repeal your ban on specific breeds of dogs (specifically pit bulls). Studies show that even people very familiar with dog breeds cannot reliably determine the primary breed of a dog by looks, and dogs are often incorrectly classified as "pit bulls." By generalizing the behaviors of dogs that look a certain way, innocent dogs suffer without ANY evidence that they pose a threat. Responsible dog owners are forced to give up their dogs or move out of your city. Cities spend money enforcing restrictions and bans instead of putting that money to better use by enforcing licensing and leash laws, and responding proactively to target owners of any dog that poses an actual risk to the community.

Based on a peer-reviewed summary prepared by the American Veterinary Medical Association Animal Welfare Division (source linked below), pit bull attacks are reported more frequently because of biases, the popularity of the breed in the area and the treatment of the animal, not because they actually happen more frequently. Based on behavioral assessments and owner surveys, the breeds found to be more aggressive towards people were small to medium-sized dogs such as the collies, toy breeds and spaniels. They also determined that responsible ownership and supervision is key to minimizing the risk of dog bites in communities, not BSL.

<https://www.avma.org/KB/Resources/LiteratureReviews/Pages/The-Role-of-Breed-in-Dog-Bite-Risk-and-Prevention.aspx>

Thank you,
Tracy Dedert
3738 Raymond Ave
Bridgeton, MO 63044

Karen Goodwin

From: Andy Wilson <andyw570@att.net>
Sent: Monday, January 30, 2017 9:06 PM
To: Karen Goodwin
Subject: B.S.L

Dear Members of the council

I am asking that you please stop and think about this action. With all the things to truly watch over and take care of in the beautiful city of Florissant does this issue really rank near the top {or at all}? Right now there is enough division and anger in this world. Don't let this ban cause more. Hold bad owners responsible not the dogs. I grew up in north county and will always be one at heart.

Please add this to your agenda. Thank you for your time.

Andy Wilson

1336 Robertridge dr

Karen Goodwin

From: Ashley Rhodes <ashnic224@gmail.com>
Sent: Tuesday, January 31, 2017 10:39 AM
To: Karen Goodwin
Subject: Please repeal the ban on pit bulls

Members of the City Council,

I am writing to request that you please repeal the ban on pit bulls in Florissant.

BSL unfairly punishes responsible pet owners without actually holding the owners of truly dangerous dogs accountable. The people who are irresponsible will simply just get another dog of a different breed and train it to be tough and aggressive.
Humans are the issue here... Not pit bulls!!

BSL has proven to be ineffective time and time again. I am begging you to please repeal the ban on pit bulls. Please end BSL.
Please stop judging the breed.

*I would also like to request that my email be added to the meeting agenda. *

Thank you so much for your time!!

Ashley Rhodes
1801 Cherry Tree St
St. Peters MO 63376

Karen Goodwin

From: Frank Bougher <fbougher10538@gmail.com>
Sent: Tuesday, January 31, 2017 5:50 PM
To: Karen Goodwin
Subject: Breed specific legislation

To the city council as a whole,
I would like to see the City of Florissant, which I live in, repeal the Breed Specific Legislation against Pit Bulls. It is unfair and unjust for a breed to be discriminated against when we all know it is the irresponsible dog owners that produce vicious dogs, not a specific breed.

Please include my email on the next city council meeting agenda. I would like a reply verifying that my email has been received and will be included on the agenda. Thank you.

Frank Bougher
1700 St. Francois St.
Florissant, MO 63033

Karen Goodwin

From: MaryRose Booher <xirishdancer@yahoo.com>
Sent: Wednesday, February 01, 2017 7:57 PM
To: Karen Goodwin
Subject: Agenda 02.13

Dear Florissant City Council Members and other staff,

I would like to request a repeal of the current Breed Specific Legislation by the City of Florissant. Please focus on the breed neutral aggressive dog ordinance. Thank you!

For Council and for Inclusion in Communications Portion of the February 13th Agenda.

MARYROSE BOOHER
1823 KINGSFORD DRIVE
FLORISSANT, MO 63031

Sent from Yahoo Mail on Android

Karen Goodwin

From: M M <ndm2385@yahoo.com>
Sent: Wednesday, February 01, 2017 8:00 PM
To: Karen Goodwin
Subject: BSL BAN

Members of the City Council,
I would like to request repeal of the ban on pit bull breeds by the city of Florissant. Please focus on the breed neutral aggressive dog ordinance. Thank you!

For Council and for Inclusion in Communications Portion of the February 13th Agenda.

Kindly,
Nichole McDonald
7260 Howdershell Road
Hazelwood, MO 63042

Karen Goodwin

From: Judy Morgan <morganjudy44@yahoo.com>
Sent: Wednesday, February 01, 2017 8:04 PM
To: Karen Goodwin
Subject: BSL Ban

Members of the City Council,
I would like to request repeal of the ban on pit bull breeds by the city of Florissant. Please focus on the breed neutral aggressive dog ordinance. Thank you!

For Council and for Inclusion in Communications Portion of the February 13th Agenda.

Kindly,
Judy Richter
36 Mallard Pointe Drive
O'Fallon, MO 63368

Karen Goodwin

From: kevin mcd <mcdeeisme@gmail.com>
Sent: Wednesday, February 01, 2017 8:09 PM
To: Karen Goodwin
Subject: BSL Ban

Members of the City Council,

I would like to request repeal of the ban on pit bull breeds by the city of Florissant. Please focus on the breed neutral aggressive dog ordinance. Thank you!

For Council and for Inclusion in Communications Portion of the February 13th Agenda.

Kindly,

Kevin McDonald
7260 Howdershell Road
Hazelwood, MO 63042

Karen Goodwin

From: jennifer harutunian <jenniferharutunian@sbcglobal.net>
Sent: Thursday, February 02, 2017 6:56 AM
To: Karen Goodwin
Subject: Please repeal pit bull ban

Hello council members:

I would like to request repeal of the ban on pit bull breeds by the city of Florissant. Please focus on the breed neutral aggressive dog ordinance. Thank you!

For Council and for Inclusion in Communications Portion of the February 13th Agenda.

Jennifer Harutunian

Sent from my iPhone

Karen Goodwin

From: cindy lacueva <thmper_62@yahoo.com>
Sent: Thursday, February 02, 2017 4:37 PM
To: Karen Goodwin
Subject: Pit bull ban

Being a dog owner and a pet care giver all of my life I can assure you that Pit Bulls are one of the sweetest, caring and obedient breeds of them all!

By placing this ban you are taking away citizens rights as Americans and disrupting many loving homes who love their dog (s) as a family member, not an object that can be moved and tossed around.

This ban is and will negatively effect many mentally and physically disabled citizens of Florissant who depend on their dogs for service and stability.

I am requesting that the city of Florissant repeal this unnecessary ban of Pit Bulls in your city. Please add my email and request to the meeting agenda on Feb 13, 2017

Cynthiana Echele
1278 Coral Bells Ct
St. Louis MO. 63146

Sent from Yahoo Mail on Android

Karen Goodwin

From: krikri5815 <krikri5815@yahoo.com>
Sent: Thursday, February 02, 2017 6:29 PM
To: Karen Goodwin

Please send to all council members and add to the communications section.

My name is Kris Korte and I live at 105 Clark St Florissant MO and I am asking for repeal of the pit bull ban and to focus on the existing vicious dog law!

Thank you,
Kristin Korte

Sent from my Sprint Samsung Galaxy Note5.

Karen Goodwin

From: Mgaha2 <mgaha2@aol.com>
Sent: Friday, February 03, 2017 4:58 PM
To: Karen Goodwin
Subject: Members of the City Council

Members of the Florissant City Council,

Please add my email request to the next City Council meeting agenda.

I was once a resident of Florissant. Now, I reside in Overland with my pit bull mix. He is a 2 year old, 35lb, super gentle dog. Definitely NOT a danger to me, my family or neighbors. Please repeal the ban on pit bulls. If for no other reason that it will bring homeowners/taxpayers back to your city.

Sincerely,
Miriam Atlee
1937 O'Connell Ave
Overland, MO 63114

Karen Goodwin

From: Jeff Cook <jeffc9801@gmail.com>
Sent: Thursday, February 02, 2017 8:42 AM
To: City Council; Mayor Schneider; Bob Russell
Subject: Plaza Madrid

Jeff Cook
2 Bridle Path Ct
Florissant, MO 63033

Dear Mayor Schneider and City Council members, and Mr. Russell,

Please don't think of this as anything other than a concern, it's not an attack or anything like that.

I am writing in regards to my concerns over Plaza Madrid. As most of you know this has been a long time concern of mine. I recently drove through the parking lot, and took a look at the shopping center, the lot, and surrounding businesses and felt compelled to inquire about this eye sore once again.

Not only is this old shopping center an eye sore, it seems like it would be a safety hazard as well. The furniture store seems to have only one working entrance, the speed bumps are crumbling, and the building itself looks like it has not been maintained properly for years. I don't understand how they are getting away with this.

Numerous times over the past 10 years or so I have inquired about this property. Two of the current council members, in wards 8 and 9 have told me that plans are in the works, but could not be discussed. Former councilman for ward 9, Ben Hernandez simply agreed that something needed to be done and he was trying to work on it. I don't know if plans fell through, or if there ever were any plans to begin with, but as a nearby resident I see and feel the effects this plaza has had on our city and I am fed up with nothing being done about it.

I had been also told at one point that there was a potential developer for the area but they backed out because of the Ferguson stuff. I am not saying I don't believe that, it is very realistic, but I would like to know what the city is doing to try and attract other developers, etc to the area if anything at all.

Is the city actively pursuing another developer? Or are we simply letting it sit there and make our beautiful city look like a joke? I know people who won't come anywhere near that area because they feel unsafe.

And speaking of unsafe, that Phillips 66 on Parker Spur is a nightmare. Some of the pumps have duct tape holding the credit card slots in place, you can barely read the digits, and 99% of the time there is an empty car running with the stereo blasting. I thought this station was being renovated.

Basically I want to know what the city is doing, about Plaza Madrid, if anything. If the city is not doing anything about it, why not? What can be done about it?

I know for a fact residents in this part of town want something done about this. I also know Mr. Siam made a lot of promises when he ran for council in ward 9 that people are waiting to see results from. I may not be in ward 9 anymore, but I am within walking distance to Plaza Madrid and I am majorly disappointed that nothing has been done.

For those who are members of the I Care About Florissant page, I posted about this. I hope to gain some support for getting the city to do something about this property as well. Feel free to look over the comments on the page. I hope that the city is willing to take action on a big concern for many residents.

Thank you for your time.

--

Thanks,
Jeff Cook

CITY OF FLORISSANT



PUBLIC HEARING NOTICE

Notice is hereby given in accordance with Section 405.135 of the Florissant City Code, the Zoning Ordinance, as amended, that a Public Hearing will be held by the City Council of the City of Florissant, St. Louis County, Missouri, in the Council Chambers, 955 rue St. Francois, on Monday, February 13, 2017 at 7:30 P.M. on the following proposition, to wit:

To issue an amendment to B-5 Ordinance No. 6868 to allow for a new sit-down carry-out restaurant with signage, for the property located at 2180 N Highway 67 (legal description to govern). Citizens and parties of interest will have the opportunity to be heard at said public hearing. Anyone with special needs should contact the City Clerk at least 5 days before said public hearing by calling 839-7630 or TDD 839-5142.

Karen Goodwin, MMC City Clerk.

1

MEMORANDUM

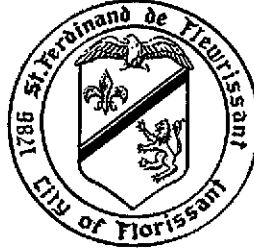

2

3 **CITY OF FLORISSANT- BUILDING DEPARTMENT**

4 *"Preserve and improve the health, safety, and welfare of our residents, businesses and the general public in the City of Florissant;*
5 *while at the same time maintaining property values and improving the quality of life in the City of Florissant."*

6

7 To: Planning and Zoning Commissioners Date: January 11, 2017

8

9 From: Philip E. Lum, AIA-Building Commissioner c: Louis B. Jearls, Jr. - P.E.,
10 PWLF Director Public Works
11 Deputy City Clerk
12 Applicant
13 File
14

15 Subject: Request recommended approval to amend a 'B-5', ordinance 6868, to
16 allow for a new sit-down, carryout restaurant at **2180 N. Highway 67,**
17 **McAlister's Deli.**
18

19 **STAFF REPORT**
20 **CASE NUMBER PZ-011717-2**

21

22 **I. PROJECT DESCRIPTION:**

23

24 This is a request for **recommended approval** to amend a 'B-5'. Exterior modifications
25 include a new patio dining area and exterior changes at **2180 N. Highway 67**. This
26 amendment would change the conditions of ordinance no. 6868, however, the use is to
27 remain restaurant, already permitted under the ordinance.
28

29 **II. EXISTING SITE CONDITIONS:**

30 The existing property was already developed for Bob Evans, another restaurant use.

31

32 This review pertains to the modifications and changes to the restrictions relating to the
33 new work proposed.
34

35 **III. SURROUNDING PROPERTIES:**

36 The property adjacent and to the South is #1 Paddock Hills Shopping Center in a 'B-3'
37 Extensive Business District, the US Bank to the West and the Rally's to the East are in a
38 'B-5' Planned Commercial District.
39
40

41 **IV. STAFF ANALYSIS:**

42 The application is accompanied by professionally completed development plans
43 including:

44
45 C1-01 Cover Sheet, C2-0 Site Plan, C3-01 Landscape Plan, dated 12/9/16
46 by MB Engineering.

47
48 Existing Boundary Adjustment survey 1 and 1 of 2, dated February 2003 by Bax
49 Engineering.

50
51 **McAlister's Deli** drawings: A1.0 Floor Plan dated 12/29/16 and A2.0 Elevations, dated
52 1/4/17.

53
54 Sign Package, marked revision 1, by Design Team Sign Co., LLC, various dates.

55
56
57 The following are staff comments regarding plans:

58
59 **C1-01 Cover Sheet Comments:**

- 60 1. Notes contain details of the development.
- 61 2. Required site sections shown.
- 62 3. Parking Calculations indicate 68 required spaces and 71 provided.
- 63 4. There is an existing post sign, with no indications of a change.

64
65 **C2-0 Site Plan Comments:**

- 66 5. Existing parking complies with new parking ordinance with the exception of the
67 north row of parking, the location which encroaches about 4 feet into the front
68 yard setback line.
- 69 6. A concrete dining patio is shown in proximity to existing utility lines, a gas line is
70 shown re-routed to allow for the construction. Primary exit doors are shown in
71 bold all with elevation about 517.00. The elevation of the grade next to the patio
72 is at elevation 514.75 and the west edge of the proposed patio at 516.90, therefore,
73 the patio does not require a guard and is sufficiently higher than grade, about 2'-
74 2" to question the effectiveness of any additional bollards for patio diner
75 protection.

76
77 **C3-01 Landscape Plan Comments:**

- 78 7. Indicates proposed replacement of landscaping displaced by the patio.

79
80 **A1.0 Floor Plan Comments:**

- 81 8. Indicates Patio seating of 48, trash screening area with gates, interior layout and
82 awning overhangs.
- 83 9. An opening in the railing is shown and notes that adjust the grade to connect to a
84 concrete walk leading to the rear of the property.

87 **A2.0 Elevation Comments:**

- 88 10. Rear Elevation: Dark Bronze areas on the drawings faintly show joints as if they
89 are metal panel joints on the trash screen gates and walk-in cooler wall.
90 11. Front Elevation: Tower is 25 feet tall with new signage, green awnings and patio.
91 12. Left Side Elevation shows EIFS panel areas painted to match dark bronze metal
92 on rear of building.
93 13. Right Side Elevation also shows existing gooseneck light fixtures to be painted
94 black.

95
96 **Sign Package Comments:**

- 97 14. McAlister's Deli main sign is deemed to be an open letter sign. Calculation is 2/3
98 total boxed area, or $63 \times .67 = 42$ s.f. Wall signs are limited to 40 s.f. except as
99 permitted under a 'B-5'.
100 15. Awning drawing dated 10/18/16 does not match architect's elevations. A 42"
101 guard rail is not required, therefore, the railing shown is for added safety and
102 containment.

103
104 **VI. STAFF RECOMMENDATIONS:**

105 **Suggested Motion-** I move to recommend approval to amend a 'B-5', ordinance 6868, to
106 allow for a new sit-down, carryout restaurant at **2180 N. Highway 67, McAlister's Deli.**
107 with the following amendments to ordinance no. 6868:
108

109 The drawing attachments for this development shall be:

- 110 a. C1-01 Cover Sheet, C2-01 Site Plan, C3-01 Landscape Plan, dated 12/9/16
111 by MB Engineering.
112 b. **McAlister's Deli** drawings: A1.0 Floor Plan dated 12/29/16 and A2.0 Elevations,
113 dated 1/4/17.
114 c. Sign Package, marked revision 1, by Design Team Sign Co., LLC, various dates.
115

116 All Alterations to the exterior, shall be implemented as indicated on the attached plans.
117

118 **7. FINAL SITE DEVELOPMENT PLAN**

119 A final site development plan shall be submitted to the Building
120 Commissioner to review for compliance with the applicable "B-5"
121 Planned Commercial Development ordinance prior to recording. Any
122 variations from the ordinance approved by the City Council and/or the
123 conceptual plans attached to such ordinance shall be processed in
124 accordance with the procedure established in the Florissant Zoning Code.
125

126 **8. AMENDMENTS TO THE SITE AND EXTERIOR BUILDING PLANS:**

127 Any changes to the approved plans attached hereto must be reviewed by the
128 Building Commissioner. The Building Commissioner must make a determination
129 as to the extent of the changes per the following procedure:
130

- 131 1. The property owner or designate representative shall submit in writing a
132 request for an amendment to the approved plans. The building

133 commissioner shall review the plans for consistency with the purpose and
134 content of the proposal as originally or previously advertised for public
135 hearing and shall make an advisory determination.

- 136 2. If the building commissioner determines that the requested amendment is
137 not consistent in purpose and content with the nature of the purpose as
138 originally proposed or previously advertised for the public hearing, then
139 an amendment to the special use permit shall be required and a review
140 and recommendation by the planning and zoning commission shall be
141 required and a new public hearing shall be required before the City
142 Council.
- 143 3. If the building commissioner determines that the proposed revisions are
144 consistent with the purpose and content with the nature of the public
145 hearing then a determination of non-necessity of a public hearing shall be
146 made.
- 147 4. Determination of minor changes: If the building commissioner determines
148 that an amendment to the special use permit is not required and that the
149 changes to the plans are minor in nature the Building Commissioner may
150 approve said changes.
- 151 5. Determination of major changes: If the Building Commissioner
152 determines that an amendment to the B-5 is not required but the changes
153 are major in nature, then the owner shall submit an application for review
154 and approval by the Planning and Zoning commission.

155
156 **9. VERIFICATION PRIOR TO OCCUPANCY PERMIT**

- 157 a. Any new roadway improvements shall be completed prior to the issuance
158 of any final occupancy permit.
- 159
- 160 b. Any new stormwater detention shall be completed prior to the issuance of
161 any occupancy permit.
- 162
- 163 c. All fencing and/or landscaping intended as screening properties shall be
164 completed prior to the issuance of any occupancy permit, unless remitted
165 by the Director of Public Works due to weather related factors.

166
167 **10. GENERAL DEVELOPMENT CONDITIONS.**

- 168 a. Unless, and except to the extent, otherwise specifically provided herein,
169 development shall be effected only in accordance with all ordinances of
170 the City of Florissant.
- 171
- 172 b. The Department of Public Works shall enforce the conditions of this
173 ordinance in accordance with the Final Site Development Plan approved
174 by the Planning & Zoning Commission and all other ordinances of the
175 City of Florissant.

176
177 **9. PROJECT COMPLETION.**

178
179
180
181
182

Construction shall start within 90 days of the issuance of building permits for the project and shall be developed in accordance of the approved final development plan within 6 months of start of construction.

(End of report and suggested motion)

FLORISSANT PLANNING & ZONING COMMISSION APPLICATION

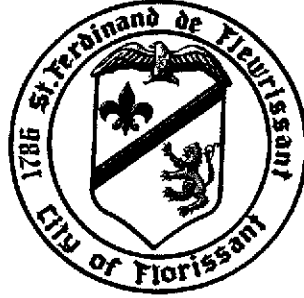

City Of Florissant - Public Works
314-839-7648

Application is hereby made to the Building Commissioner of the Department of Public works Office at the City of Florissant, Missouri, to appear before the Planning & Zoning Commission

Please Print or Type The Following Information

Property Address: 2180 N. Highway 67

Property Owners Name: Musarra 162 LLC Phone #: _____

Property Owners Address: P.O. Box 1911, Williamsville, NY 14231-1911

Business Owners Name: Southern Rock Restaurants, LLC Phone #: 615-202-5040

Business Owners Address: 1881 General George Patton Drive Suite 107, Franklin, TN 37067

DBA (Doing Business As) McAlister's Deli

Authorized Agents Name: Michael Mueller CO. Name: MB Engineering, Inc.
(Authorized Agent to Appear Before The Commission)

Agents Address: 768 Glen Mor Drive, Belleville, IL 62221 Phone #: 618-954-0255

Request Amend the site specific B-5 ordinance to allow for the McAlister's Deli with outdoor patio seating area.

State complete request (print or type only).

IF A TRAFFIC STUDY IS REQUIRED FOR CERTAIN DEVELOPMENTS AND USES THE COST OF THE TRAFFIC STUDY SHALL BE PAID BY THE APPLICANT. PLEASE SUBMIT FOLDED PLANS

Michael Mueller
Applicant's Signature

1/4/2017
Date

Received by: CT Receipt # 598123 Amount Paid: \$125.00 Date: 1/5/17

OFFICE USE ONLY

STAFF REMARKS: _____

DATE APPLICATION REVIEWED: _____

SIGNATURE OF STAFF WHO REVIEWED APPLICATION

COMMISSION ACTION TAKEN:

RECOMMENDED APPROVAL
PLANNING & ZONING
CHAIRMAN

SIGN. Paul Hon DATE: 1/17/17

APPLICATION TO THE CITY OF FLORISSANT PLANNING AND ZONING COMMISSION TO ESTABLISH A B-5 PLANNED COMMERCIAL DISTRICT

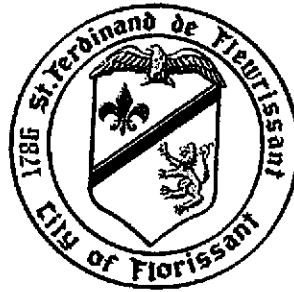

PLANNING & ZONING ACTION:

RECOMMENDED APPROVAL
PLANNING & ZONING
CHAIRMAN

SIGN.

DATE: 1/17/17

Address of Property:

2180 N. Highway 67

Council Ward _____ Zoning _____

Initial Date Petitioner Filed _____
Building Commissioner to complete
ward, zoning & date filed

PETITION FOR A B-5 RE-ZONING:

1) Comes Now Southern Rock Restaurants, LLC /dba McAlister's Deli
(Individual's name, corporation, partnership, etc.)
Enter name of petitioner. If a corporation, state as such. If applicable include DBA (Doing Business As).

and states to the Planning and Zoning Commission that he (she) (they) has (have) the following legal interest in the tract of land located in the City of Florissant, State of Missouri, described on page 3 of this petition.

Legal interest in the Property Lease
State legal interest in the property. (i.e., owner of property, lease); also submit copy of deed or lease or letter of authorization from owner to seek a special use.

- A. The petitioner (s) hereby states that he (she) (they) is (are) submitting a description of the property for which the Permit is petitioned by giving bearings & distances (metes and bounds). Not required if description is identical to "B".
- B. The petitioner (s) hereby states that he (she) (they) is (are) submitting a survey or plat of the property drawn to a scale of 100 feet or less to the inch, referenced to a point easily located on the ground as street intersection, centerline of creek having a generally known name, etc., showing dimensions, bearings and distances of the property, north arrow and scale.
- C. Acreage to nearest tenth of an acre of the property for which rezoning is petitioned 1.3 Acres
- 2. The petitioner(s) hereby further state(s) that the property herein described in this petition is presently zoned in a B5 District and is presently being used for: Bob Evans Restaurant (vacant)

State current use of property, (or, state: vacant).

3. The petitioner(s) hereby state(s) the following purpose to justify the re-zoning to a B-5:
McAlister's Deli

List purpose for this request.

4. The petitioner(s) further states(s) that they (he) (she) can comply with all of the requirements of the City of Florissant, including setback lines and off-street parking.
5. The petitioner(s) further state(s) that they (he) (she) further represent(s) and warrants that they (he) (she) has (have) not made any arrangement to pay any commission, gratuity or consideration, directly or indirectly, to any official employee or appointee of the City of Florissant, with respect to this application.

PRINT PETITIONER'S NAME David R. Blackburn

Print Name

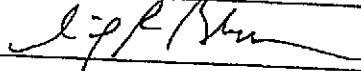
PETITIONER(S) SIGNATURE (S) 

FOR Southern Rock Restaurants, LLC
(company, corporation, partnership)

Print and sign application. If applicant is a corporation or partnership signature must be a CORPORATE OFFICER or LLC Managing PARTNER. NOTE: Corporate officer is an individual named in corporate papers.

6. I (we) hereby certify that (indicate one of the following):
 I (we) have a legal interest in the herein above described property.
 I am (we are) the duly appointed agent(s) of the petitioner (s), and that all information given here is true and a statement of fact.

Petitioner may assign an agent to present petition to the Commission and Council. The agent must sign the petition in this section, and provide address and telephone number

SIGNATURE 

ADDRESS 768 Glen Mor Drive Belleville IL 62221
STREET CITY STATE ZIP CODE

TELEPHONE NUMBER 618-954-0255
BUSINESS

I (we) the petitioner (s) do hereby appoint Michael Mueller of MB Engineering, Inc. as
my (our) duly authorized agent to represent me (us) in regard to this petition.
Print name of agent.

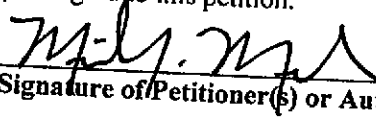
Signature of Petitioner(s) or Authorized Agent

NOTE: Be advised when the petitioner and/or his duly authorized agent appears before the Planning and Zoning Commission and make the presentation, the same individuals must also appear before the City Council for that presentation. Also if the descriptions of plats or surveys are incorrect, or if the petition form is not correctly and completely filled out it will be returned for corrections and may have to be re-submitted.

Please check the box for the appropriate type of operation then fill in applicable section (a), (b) or (c). Corporations are to submit copy of Missouri corporate papers with registration papers.

1) Type of Operation: Individual: Partnership: Corporation/LLC:

(a) If an Individual:

- (1) Name and Address _____
- (2) Telephone Number _____
- (3) Business Address _____
- (4) Date started in business _____
- (5) Name in which business is operated if different from (1) _____
- (6) If operating under a fictitious name, provide the name and date registered with the State of Missouri, and a copy of the registration.

(b) If a Partnership:

- (1) Names & addresses of all partners _____
- (2) Telephone numbers _____
- (3) Business address _____
- (4) Name under which business is operated _____
- (5) If operating under fictitious name, provide date the name was registered with the State of Missouri, and a copy of the registration.

(c) If a Corporation or LLC:

- | | | |
|--|---|-----------------------------|
| | David R. Blackburn | Lisa Mathis |
| | 805 Stalcup Court | 2615 Westerham Way |
| (1) Names & addresses of all partners | Franklin, TN 37064 | Thompsons Station, TN 37179 |
| (2) Telephone numbers | Mr. Blackburn: 615-202-5040 | Ms. Mathis: 615-351-3036 |
| (3) Business address | 1881 General George Patton Dr., Suite 107, Franklin, TN 37067 | |
| (4) State of corporation & a photocopy of incorporation papers | Delaware | |
| (5) Date of corporation | May 5, 2011 | |
| (6) Missouri Corporate Number | FL1154035 | |
| (7) If operating under fictitious name, provide the name and date registered with the State of Missouri, and a copy of registration. | Southern Rock Restaurants, LLC /dba McAlister's Deli | |
| (8) Name in which business is operated | McAlister's Deli | |
| (9) If the property location is in a strip center, give dimensions of your space under square footage and do not give landscaping information. | | |

Please fill in applicable information requested.

Name David R. Blackburn

Address 1881 General George Patton Dr., Suite 107, Franklin, TN 37067

Property Owner Musarra 162 LLC, a Colorado LLC

Location of property 2180 N. Highway 67

Dimensions of property 287' x 177' (Irregular)

Current Use of Property vacant Bob Evans Restaurant

Proposed Use of Property McAlister's Deli

Type of Sign Monopole Height 25'

Type of Construction V-B Number Of Stories 1

Square Footage of Building 5,120 s.f. Number of Curb Cuts 2 (existing)

Number of Parking Spaces 71 Sidewalk Length 118'

Landscaping: No. of Trees Existing trees to remain Diameter _____
No. of Shrubs Existing shrubs to remain, except at new patio location Size _____

Fence: Type N/A Length _____ Height _____

PLEASE SUBMIT NINE (9) FOLDED COPIES OF THE FOLLOWING:

1. Plan or drawing showing zoning of adjoining properties.
2. Plan or drawing showing location of property in relation to major streets and all adjoining properties.
3. Drawing showing measurement of tract and overall area of tract.
4. Plan or drawing showing proposed parking layout, landscaping, parking lighting, signage and trash enclosure.

STAFF CHECK LIST / REVIEW SHEET

ADDRESS OF PROPERTY 2180 N Hwy 67 CURRENT ZONING _____

PROPERTY OWNER OF RECORD _____ PHONE NO. _____

AUTHORIZED AGENT _____ PHONE NO. _____

PROPOSAL Amend 'B5.' for McAlister

- 1) a. Uses - Are uses stipulated Yes / No
- b. What current District would this proposal be a permitted use: B-5
- c. Proposed uses for out lots: _____

2) Performance Standards:

- a) Vibration: Is there any foreseen vibration problems at the property line? Yes / No
- b) Noises: Will the operation or proposed equipment exceed 70 decibels? Yes / No
- c) Odor is there any foreseen problem with odor? Yes / No
- d) Smoke: Will the operation emit any smoke which could exceed a density described as No. 1 on the Ringleman Chart? Yes / No
- e) Toxic gases: Is there any foreseen emission of toxic gases from the operation? Yes / No
- f) Is there foreseen emission of dirt, dust, fly ash, and other forms of particle matter? Yes / No
- g) Is there any dangerous amount of radiation produced from the operation? Yes / No
- h) Is there any glare or heat which would be produced outside of an enclosure? Yes / No
- i) Is screening of trash dumpsters, mechanical equipment, incinerators, etc, shown? Yes / No
- j) Is buildings screened from adjoining residential? Yes / No

- 3) Are height of structures shown? Yes / No
- 4) Are all setbacks shown? Yes / No
- 5) Are building square footages shown? Yes / No
- 6) What is the exterior construction of the buildings? Yes / No
- 7) Is off street loading shown? existing mas.

- 8) Parking:
 - a) Does parking shown meet the ordinance? Yes / No
 - b) Is a variance required in accordance with the ordinance? Yes / No
 - c) Ratio shown _____ to _____ study req'd.
 - d) Total Number _____ 75
 - e) Will cross access and cross parking agreements be required? Yes / No
 - f) Is the parking lot adequately landscaped? Yes / No

- 9) Are there any signs?
 - Number of signs shown _____ Yes / No
 - Type of Signs (2) Yes / No
 - Are sizes, heights, details, and setbacks shown? 1 post (2) wall Yes / No

- 10) Are existing and proposed contours shown at not more than five (5) feet intervals? Yes / No
- 11) Is the approximate location of all isolated trees having a trunk diameter of six inches or all tree masses and proposed landscaping shown? Yes / No

- 12) Are two section profiles through the site showing preliminary building form, existing natural grade and proposed final grade shown? Yes / No
- 13) Is proposed ingress/egress onto the site and internal traffic movements shown? Yes / No
- 14) Was a traffic study submitted?
Does the City Staff recommend a traffic study? Yes / No
- 15) Are preliminary plans for sanitation and drainage (sanitary & storm water) facilities shown? Yes / No existing
- 16) Is a legal description of the property shown?
Does legal description appear to be proper? Yes / No
- 17) Is an out-boundary plat of the property submitted? Yes / No
- 18) Suggested time limitations of construction: Start _____ ? _____ Finish _____ ? ? 12 mos?
- 19) Is parking lot lighting shown? Yes / No existing
- 20) Are new walkways required? Yes / No
- 21) Is there sufficient handicapped access? Yes / No
- 22) a) Are there proposed curb-cuts?
b) Do the curb-cuts meet the City ordinances? Yes / No
Yes / No N/A
- 23) Will this project require any street improvements? Yes / No Lindbergh
improvement
landscape
- 24) Staff recommendations for site development plans: _____

- 25) Staff Comments: _____

1/3/17
Date Application reviewed

Philip Ellis
Building Commissioner or Staff Signature



Sales: Rhonda Lambert
Project Manager:
2180 N HWY 67
Florissant, MO 63033

Table of Contents

- Page 1 -Cover Page
- Page 2 -Front Elevation
- Page 3 -East Elevation
- Page 4 -West Elevation
- Page 5 -48" Direct Mount Channel Letters
- Page 6 - Louvered Window Awnings
- Page 7 -Door Vinyl
- Page 8 -Patjo Railing

Revision Notes

Rev # 1

**RECOMMENDED APPROVAL
PLANNING & ZONING
CHAIRMAN**

SIGN:

DATE: 11/17/17



Courtesy of

SIGN COMPANY LLC.
731-925-4448 • 800-953-3744 • Fax 731-925-2022
www.designteam.net

Front Elevation

A	48" Direct Mount Channel Letters
B	73"x83" Window Awnings
C	New Door Vinyl
D	Patio Railing

Rev 1
Rev 2
Rev 3
Rev 4
Rev 5
Rev 6

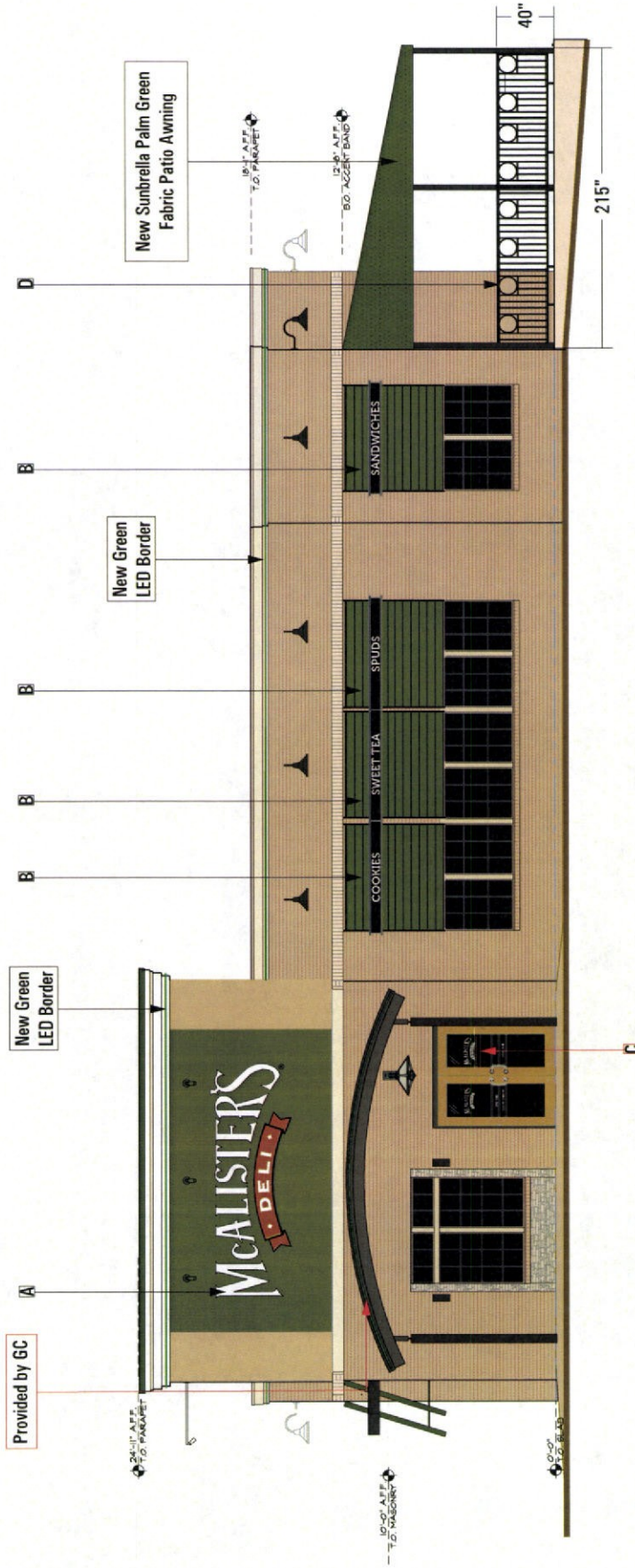

Designer: CM	Date: 1/9/16	Option # 1 - CM
Client: McAlister's of Florissant, MO		
File Path: Z:\restaurant\McAlisters\Florissant\MO\Elevation		

- Proof is Approved. Proceed With Production Of Order
- Proof is Approved With Corrections. Make Corrections As Indicated And Proceed With Production Of Order

Signature: _____
 I have reviewed this proof in regard to: Sign type, order quantity, and accuracy of icons, symbols, and text (i.e., spelling capitalization, punctuation).
 Print Name: _____
 Date: _____



These plans are the exclusive property of Design Team Sign Company and are the result of the original work of its employees. They are submitted to your company for the sole purpose of providing you with a visual representation of the product manufactured according to these plans. Distribution or use of these plans for any other purpose without the written consent of Design Team Sign Company is strictly prohibited. In the event you are unable to contact Design Team Sign Company for any reason, you are expected to be reimbursed \$500 in compensation for time and effort entailed in creating these plans.

East Elevation

A	48" Direct Mount Channel Letters
B	73"x83" Window Awnings
C	New Door Vinyl
D	Patio Railing

Rev 1
Rev 2
Rev 3
Rev 4
Rev 5
Rev 6

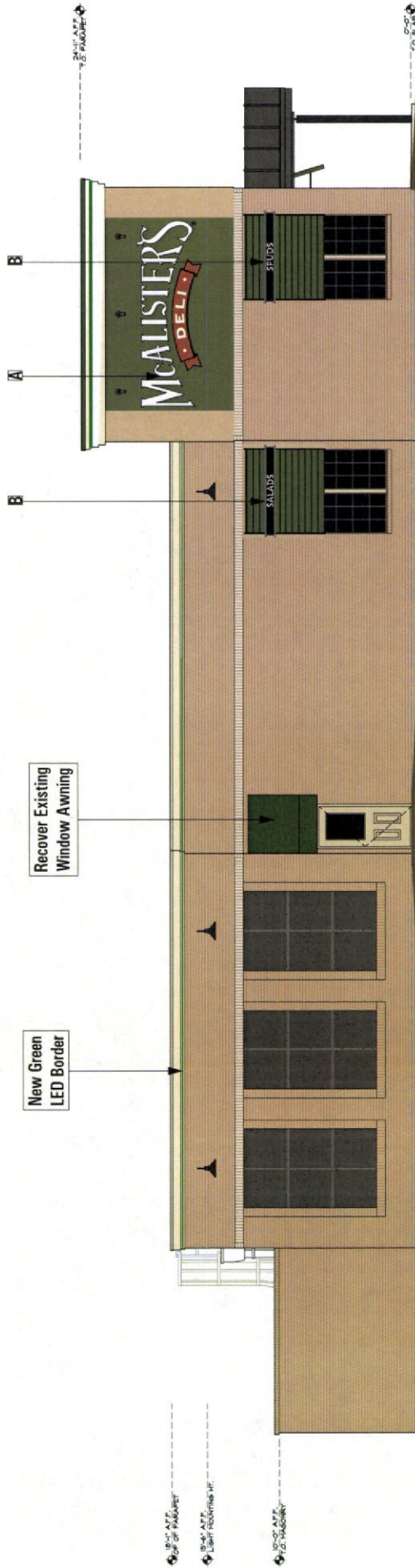

Designer: CM	Date: 1/9/16	Option # 1 - CM
Client: McAlister's of Florissant, MO		
File Path: Z:\restaurant\McAlister's\FlorissantMO\Elevation		

- Proof is Approved. Proceed With Production Of Order
- Proof is Approved With Corrections. Make Corrections As Indicated And Proceed With Production Of Order

Signature: _____
 I have reviewed this proof in regard to: Sign type, order quantity, and accuracy of colors, symbols, and text (i.e., spelling, abbreviation, punctuation).
 Print Name: _____
 Date: _____



These plans are the exclusive property of Design Team Sign Company and are the result of the original work of its employees. They are submitted to your company for the sole purpose of providing you with a visual representation of the product manufactured according to these plans. Distribution or reproduction of these plans without the express written consent of Design Team Sign Company is prohibited. Design Team Sign Company expects to be reimbursed \$500 in compensation for time and effort entailed in creating these plans.

West Elevation

Rev 1
Rev 2
Rev 3
Rev 4
Rev 5
Rev 6

D | Patio Railing

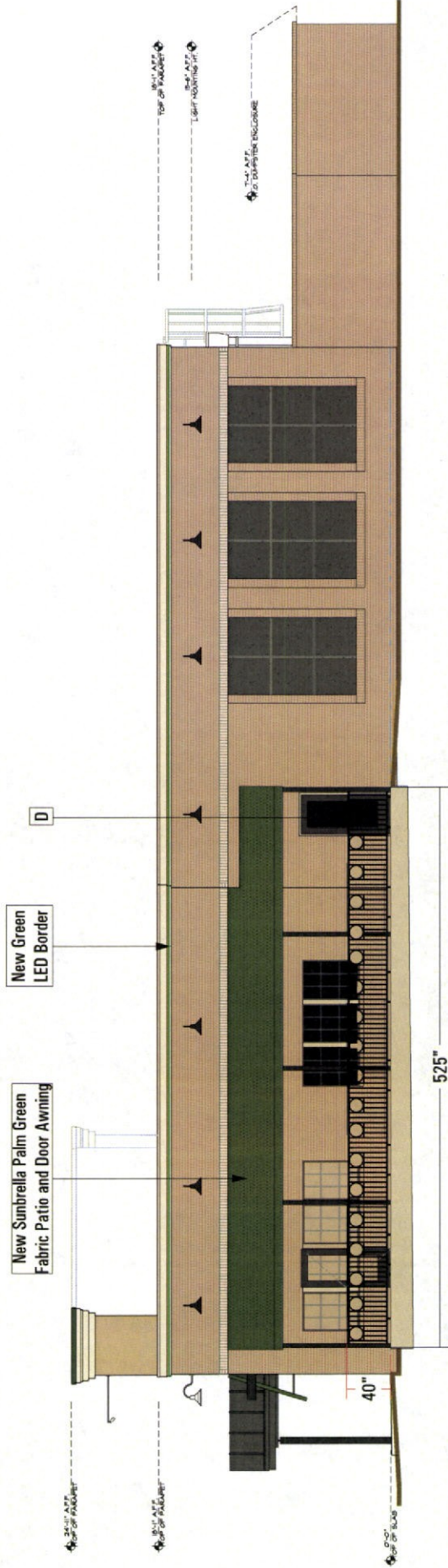

These plans are the exclusive property of Design Team Sign Company. They are submitted to your company for the sole purpose of providing a design for your company. No part of these plans or the product manufactured according to these plans, Distribution or use of these plans, or use of these plans to construct a product similar to one envisioned herein, is expressly forbidden. In the event your company expects to be reimbursed \$500 in compensation for time and effort entailed in creating these plans.



Signature: _____
 I have reviewed this proof in regard to: Sign type, color, quantity, and accuracy of icons, symbols, and text (e.g., spelling, capitalization, punctuation).
 Print Name: _____
 Date: _____

- Proof is Approved. Proceed With Production Of Order
- Proof is Approved With Corrections. Make Corrections As Indicated And Proceed With Production Of Order

Designer: CM	Date: 1/9/16	Option # 1 - CM
Client: McAlister's of Florissant, MO		
File Path: Z:\restaurant\McAlistersFlorissantMO\Elevation		



Direct Mount Channel Letters

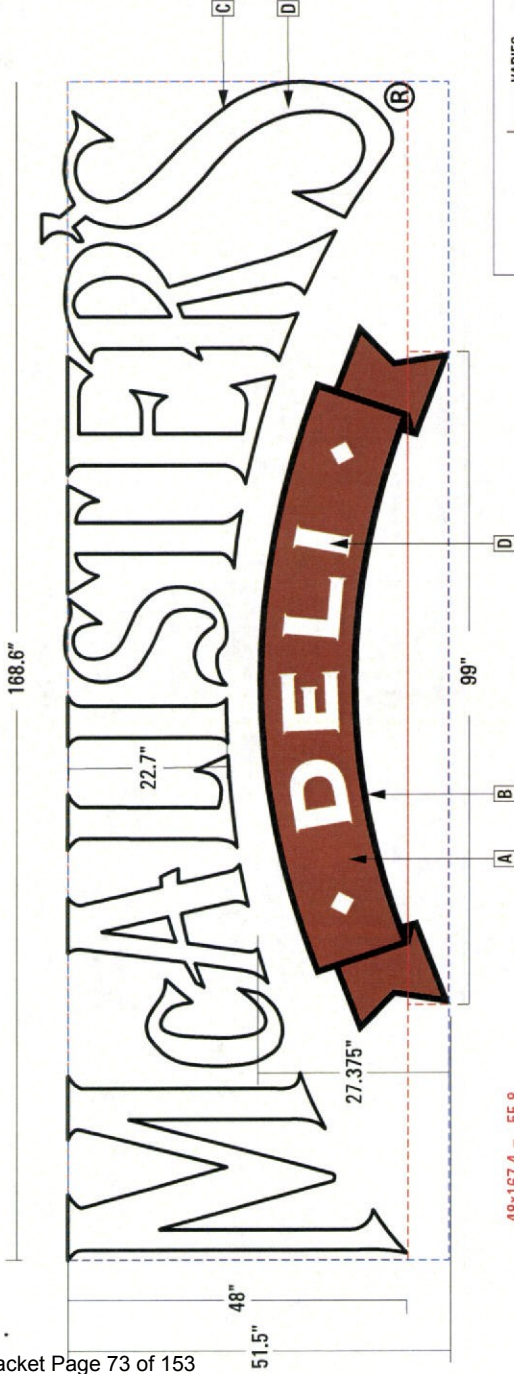

$48 \times 167.4 = 55.8$
 $5.7 \times 93 = 3.68$
Total Actual SQ. FT. = 59.48
 $54.2 \times 167.4 = 63$
Total Boxed SQ. FT. = 63

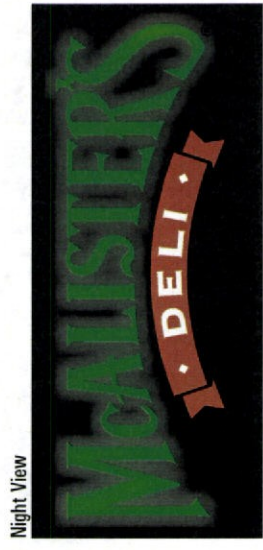

Materials	
1.	.040 Aluminum Returns
2.	1" Trimcap
3.	3/16" - 2447 White Acrylic Face
4.	.090 Aluminum Back
5.	Letters: Green LED - Ribbon: White LED
6.	Mounting Hardware
7.	1/4" Weep Hole
8.	1/2" Flex Conduit
9.	Toggle Switch Mounted to Box
10.	Power Supply
11.	Primary Electrical Leads
12.	Plywood

Colors & Finishes	
A	1st Surface 751-083 Nut Brown (Ribbon)
B	1st Surface Matte Black Vinyl (Ribbon)
C	Gloss Black Trim and Returns
D	2447 White Acrylic Faces
E	Green LED (McAlister's) White LED (Ribbon)

Rev # 1.	
Rev # 2.	
Rev # 3.	
Rev # 4.	
Rev # 5.	
Rev # 6.	

Notes	

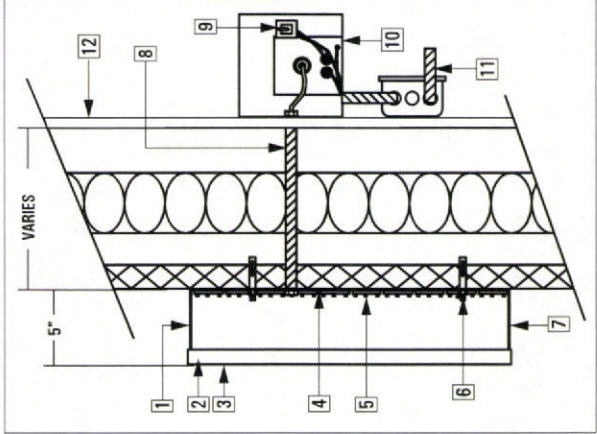

These plans are the exclusive property of Design Team Signs employees. They are submitted to your company for the sole purpose of providing a visual reference of the proposed sign or product manufactured according to these plans. Distribution or use of these plans without Design Team Signs' permission is strictly prohibited. In the event you are unable to contact Design Team Signs, please notify your company, or use of these plans to construct a product similar to one embodied herein, is expressly forbidden. In the event you are unable to contact Design Team Signs, please notify your company. Company expects to be reimbursed \$500 in compensation for time and effort expended in creating these plans.



Signature: _____
 Print Name: _____
 Date: _____

- Proof Is Approved, Proceed With Production Of Order
 Proof Is Approved With Corrections, Make Corrections As Indicated And Proceed With Production Of Order

Designer: MEB	Date: 9/29/15
Client: McAlister's	
File Path: z:\Restaurant\McAlister's/CorporateStandards	



Louver Awning

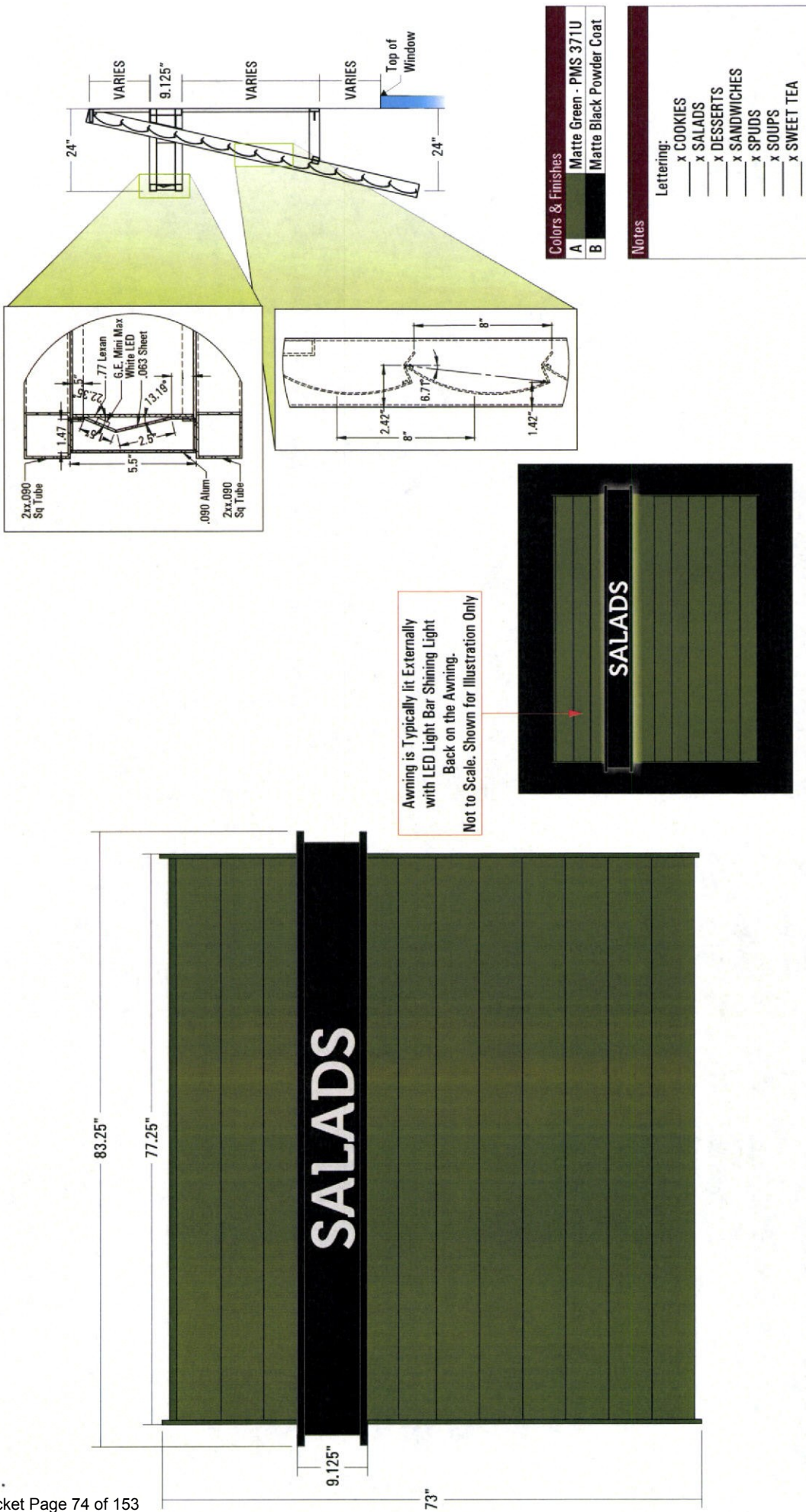

These signs are the exclusive property of Design Team Sign Company and are the result of the original work of its employees. They are submitted to your company for the sole purpose of your review and approval. No reproduction or product manufactured according to these plans, Distribution or use of these plans to construct a product similar to any combination of construction, Design Team Sign Company respects to be reimbursed \$500 in compensation for time and effort entailed in creating these plans.



Signature: _____
 I have reviewed this proof in regard to: Sign size, color, quantity, and accuracy of fonts, symbols, and text (e.g., spelling, capitalization, punctuation).
Print Name: _____
Date: _____

Proof is Approved. Proceed With Production Of Order
 Proof is Approved With Corrections. Make Corrections As Indicated And Proceed With Production Of Order

Designer: CM	Date: 1-25-16
Client: McAlister's	
File Path: z/Restaurant/McAlisters/CorporateStandards	



Suite Number Font is Arial Bold
Additional Wording is Swiss 721 BlkCn BT

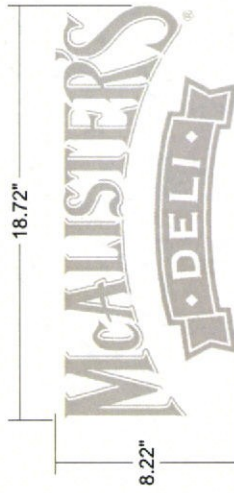
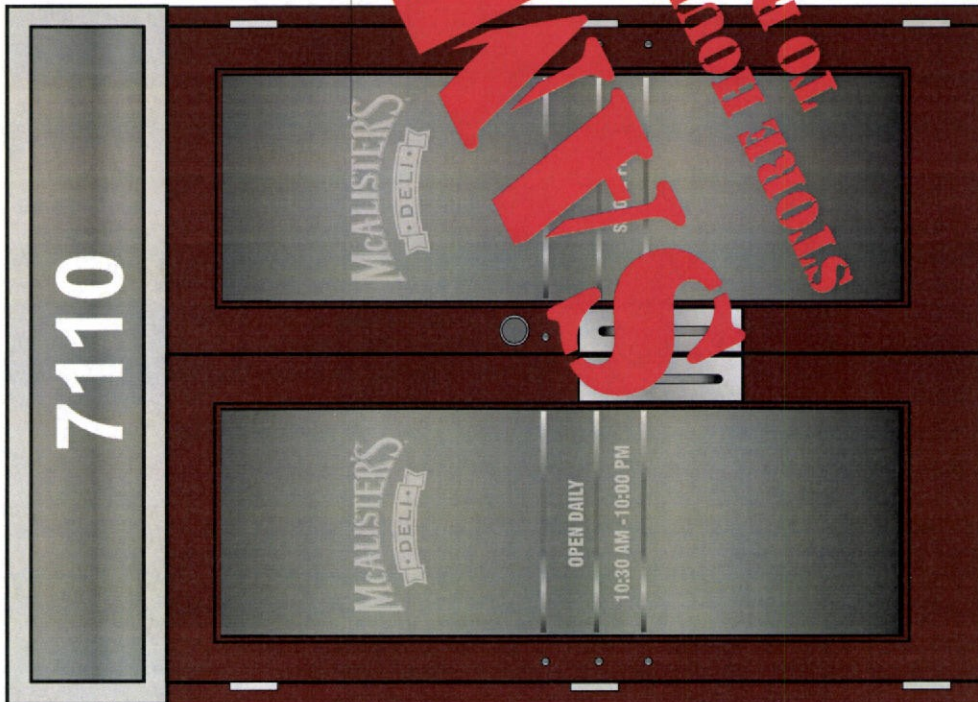

9" height
1.5" OPEN DAILY

17" height
1.4" 10:30 AM - 10:00 PM



10" height
1.5" SMOKE FREE

Specifications:

Avery SC 900-861-W Vinyl Applied
1st Surface (McAlister's Logo, Store Hours, and Smoke Free Lettering)
751-010 White Vinyl (Suite Number)

These plans are the exclusive property of Design Team Sign Company and are the result of the original work of its employees. They are submitted to your company for the sole purpose of providing you with a visual representation of the product manufactured according to these plans. Distribution or reproduction of these plans, in whole or in part, without the written consent of Design Team Sign Company, is strictly prohibited. Design Team Sign Company accepts no responsibility for any errors or omissions that may appear in these plans. All dimensions are in inches unless otherwise specified. Design Team Sign Company is not responsible for any damage to your property that may occur while installing these plans.



Signature: _____
I have reviewed this proof in regard to: Sign type, color, quantity, and accuracy of icons, symbols, and text (e.g. spelling capitalization, punctuation).
Print Name: _____
Date: _____

- Proof Is Approved. Proceed With Production Of Order
- Proof Is Approved With Corrections. Make Corrections As Indicated And Proceed With Production Of Order

Designer: MEB	Date: 9/30/15
Client: McAlister's	
File Path: z:\Restaurant\McAlister's\CorporateStandards	



Patio Railings

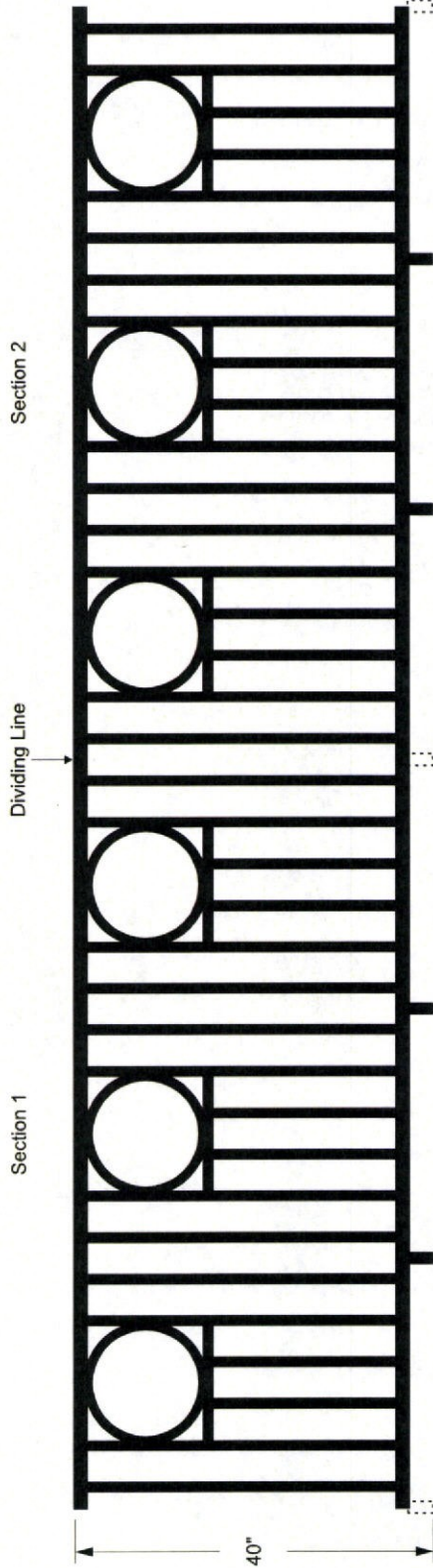

Support leg to be added between each section.
Support legs may need to be equally distributed other than shown here.

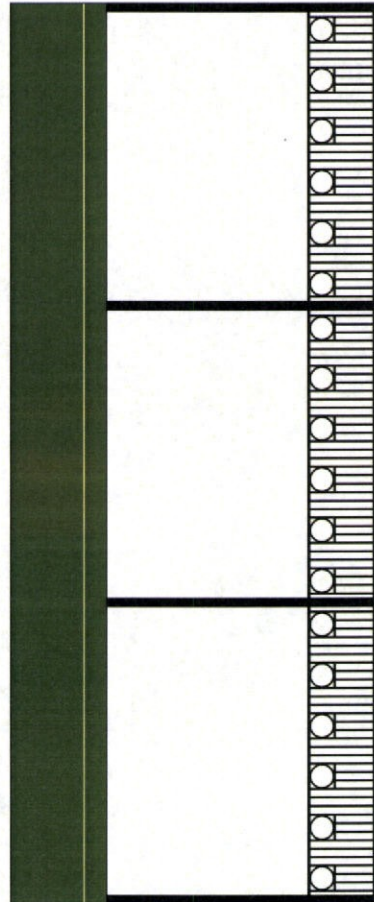

Equally distribute railings between posts.

Colors & Finishes

A Gloss Black

- Rev #1 -
- Rev #2 -
- Rev #3 -
- Rev #4 -
- Rev #5 -
- Rev #6 -

Notes



Designer: MEB Date: 10-18-16
Client: McAlister's
File Path: z/Restaurant/McA/Specs

- Proof Is Approved. Proceed With Production Of Order
- Proof Is Approved With Corrections. Make Corrections As Indicated And Proceed With Production Of Order

Signature: _____
I have reviewed this proof in regard to: Sign type, order quantity, and accuracy of fonts, symbols, and text (e.g. spelling capitalization, punctuation).
Print Name: _____
Date: _____



This proof is the exclusive property of Design Team Sign Company and are the result of the original work of its employees. They are submitted to your company for the sole purpose of your review and approval. This proof is not a product manufactured according to these plans. Distribution or use of these plans in any form, including reproduction, or use for these plans to construct a product similar to that shown herein, is expressly forbidden. In the event of any violation of copyright, Design Team Sign Company expects to be reimbursed \$1000 in compensation for time and effort involved in creating these plans.

1 INTRODUCED BY COUNCILMAN SCHILDROTH
2 JANUARY 23, 2017

3
4 BILL NO. 9255

ORDINANCE NO.

5
6 **ORDINANCE TO AUTHORIZE AN AMENDMENT TO SPECIAL**
7 **USE PERMIT NO. 4830, AS AMENDED BY ORDINANCE NOS.**
8 **5071, 5255, AND 5259 FOR THE LOCATION OF A GROUND SIGN**
9 **IN AN R-4 ZONING DISTRICT FOR THE PROPERTY LOCATED**
10 **AT 1001 DUNN ROAD.**

11
12 WHEREAS, the Florissant City Council passed and approved Ordinance No. 4830
13 authorizing a Special Permit for the location of a professional office building for the
14 property known as 1001 Dunn Road, and

15
16 WHEREAS, John Boain, DDS has filed an application to amend Special Use Permit no.
17 4830 as amended to include the modification of a ground sign; and

18
19 WHEREAS, the Planning and Zoning Commission recommended approval of the
20 amendment to the Special Permit granted in Ordinance No. 4830 as amended, and

21
22 WHEREAS, due notice of a public hearing on the application to amend the Special
23 Permit to be held on the 23rd of January, 2017 at 7:30 p.m. by the Council of the City of
24 Florissant was duly published and held; and

25
26 WHEREAS, the City Council, following said public hearing, and after due and careful
27 consideration, has concluded that the granting of an amendment to the Special Permit, as
28 authorized in Ordinance No. 4830 as amended, would be in the best interest of the City of
29 Florissant.

30
31 NOW, THEREFORE, be it ordained by the Council of the City of Florissant, St. Louis
32 County, Missouri, as Follows:

33
34 Section 1: The Special Permit previously granted in Ordinance 4830 as amended
35 by ordinance nos. 5071, 5255, and 5259, is hereby amended to allow for the installation
36 of a ground sign, internally illuminated, double sided, ground sign, as located on the
37 property in the high-lighted area in the island approach entrance according to the
38 proposal prepared by the petitioner as described in related documents and plans attached
39 hereto. Approval is subject to the regulations of the City of Florissant Building Code,
40 and the following additional requirements:

- 41
42 1. GENERAL DEVELOPMENT CONDITIONS.

43
44
45
46
47
48
49
50
51
52
53
54
55
56
57
58
59
60
61
62
63
64
65
66
67
68
69
70
71
72
73
74
75
76
77
78
79
80
81
82
83

- a. Unless, and except to the extent, otherwise specifically provided, the sign shall be effected only in accordance with all ordinances of the City of Florissant.
- b. The sign shall be located in the entrance way on the entrance island and the size shall be of the size of the internally illuminated, double sided ground drawing by Pyros Signs.

2. PROJECT COMPLETION.

- a. Construction shall start within 30 days of the issuance of building permits for the project and shall be installed in accordance of the approved construction plan within 90 days of start of construction.

Section 2: All of the other terms and conditions set forth in Ordinance 4830 as amended shall remain in full force and effect as if set forth herein.

Section 3: This Ordinance shall be in full force and effect immediately upon its passage and approval.

Adopted this _____ day of _____, 2017.

Jackie Pagano
President of the Council

Approved this _____ day of _____, 2017.

Thomas P. Schneider
Mayor

ATTEST:

Karen Goodwin, MMC/MRCC
City Clerk

CITY OF FLORISSANT

Public Hearing



In accordance with 405.310 of the Florissant Zoning Code a Public Hearing will be held by the City Council of Florissant, MO. in the Council Chambers, 955 Rue St. Francois, on Monday, January 23, 2017 at 7:30 P.M. on the following proposition:

**To authorize an amendment to Special Use Permit No. 4830, as amended by Ord. Nos. 5071, 5255, and 5259, for the location of a ground sign in an R-4 Zoning District for the property located at 1001 Dunn Road (legal description to govern). Citizens will have an opportunity to be heard. Anyone with special needs should contact the City Clerk at least 5 days before said public hearing by calling 839-7630 or TDD 839-5142. CITY OF FLORISSANT, Karen Goodwin, MMC
City Clerk**

FLORISSANT PLANNING & ZONING COMMISSION APPLICATION

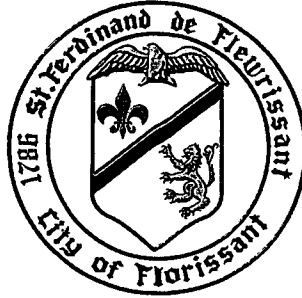

City Of Florissant – Public Works
314-839-7648

Application is hereby made to the Building Commissioner of the Department of Public works Office at the City of Florissant, Missouri, to appear before the Planning & Zoning Commission

Please Print or Type The Following Information

Property Address: 1001 Dunn Road Florissant, Mo 63031

Property Owners Name: John C. Boain DDS Phone #: 314-921-3527

Property Owners Address: 17927 Bonhomme Ridge Ct Chesterfield, Mo 63005

Business Owners Name: John C. Boain DDS PC Phone #: 314-921-3527

Business Owners Address: 17927 Bonhomme Ridge Ct Chesterfield, Mo 63005

DBA (Doing Business As) Boain Dental Care

Authorized Agents Name: John C Boain DDS CO. Name: _____
(Authorized Agent to Appear Before The Commission)

Agents Address: _____ Phone #: _____

Request Special use permit to allow Ben Place double sided monument sign 6'4" high closer to Dunn Road as trees block view and traffic is entering highway 270.
State complete request (print or type only).

IF A TRAFFIC STUDY IS REQUIRED FOR CERTAIN DEVELOPMENTS AND USES THE COST OF THE TRAFFIC STUDY SHALL BE PAID BY THE APPLICANT. PLEASE SUBMIT FOLDED PLANS

Applicant's Signature _____ Date _____

Received by: lt Receipt # 591317 Amount Paid: 125 Date: 11/14/16
OFFICE USE ONLY

STAFF REMARKS: see revised staff report 12/20/16

DATE APPLICATION REVIEWED 12/20/16
Philip C. [Signature]
SIGNATURE OF STAFF WHO REVIEWED APPLICATION

COMMISSION ACTION TAKEN:
RECOMMENDED APPROVAL
PLANNING & ZONING
CHAIRMAN

SIGN. [Signature] DATE: 1/3/2017

SPECIAL USE PERMIT APPLICATION
TO THE CITY OF FLORISSANT
PLANNING AND ZONING COMMISSION

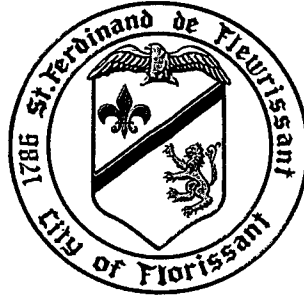

City Of Florissant – Public Works
314-839-7648

PLANNING & ZONING ACTION
RECOMMENDED APPROVAL
PLANNING & ZONING
CHAIRMAN

SIGN.

Paul J. ...

DATE: 1/3/2017

Council Ward _____ Zoning _____

Initial Date Petitioner Filed _____
Building Commissioner to complete
ward, zone & date filed

SPECIAL PERMIT FOR placement of monument sign
Statement of what permit is being sought. (i.e., special permit for operation of a restaurant.

AMEND SPECIAL PERMIT #- _____ TO ALLOW FOR _____
ordinance # Statement of what the amendment is for.

LOCATION 1001 Dunn Road Florissant, MO 63031
Address of property.

1) Comes Now John C Boain DDS, PC, Inc DBA Boain Dental Care
Enter name of petitioner. If a corporation, state as such. If applicable include DBA (Doing Business As)

and states to the Planning and Zoning Commission that he (she) (they) has (have) the following legal interest in the tract of land located in the City of Florissant, State of Missouri, as described on page 3 of this petition.

Legal interest in the Property) owner
State legal interest in the property. (i.e., owner of property, lease.
Submit copy of deed or lease or letter of authorization from owner to seek a special use.

2) The petitioner(s) further state(s) that the property herein described is presently being used for Professional Dental Services and that the deed restrictions for the property do not prohibit the use which would be authorized by said Permit.

3) The petitioner(s) further states (s) that they (he) (she) are submitting a detailed site plan of the proposed or existing development showing location and use of all structures, off-street parking, and all other information required by the Zoning Ordinance or determined necessary by the Building Commissioner.

4) The petitioner(s) further state(s) that (he) (she) (they) can comply with all of the requirements of the City of Florissant, including setback lines and off- street parking.

- 5) The petitioner (s) further (represent (s) and warrants (s) that they (he) (she) has (have) not made any arrangement to pay any commission gratuity or consideration, directly or indirectly to any official, employee or appointee of the City of Florissant, with respect to this application.
- 6) The petitioner(s) further state (s) that the Special Use Permit is sought for the following purposes, and no other, List in detail, all activities sought to be covered by the permit (i.e.; operation of a business, approval of building and / or site plans (preliminary and / or final), plan approval for sign, etc.):
- 7) The petitioner (s) state (s) the following factors and reason to justify the permit:
(If more space is needed, separate sheets maybe attached)

John C Boain, DDS *John C Boain, DDS*
 PRINT NAME SIGNATURE

FOR John C Boain DDS, PC, Inc DBA Boain Dental Care
 (company, corporation, partnership)

Print and sign application. If applicant is a corporation or partnership signature must be a CORPORATE OFFICER or a PARTNER. NOTE: Corporate officer is an individual named in corporate papers.

- 8) I (we) hereby certify that (indicate one of the following):
- I (we) have a legal interest in the herein above described property.
- I am (we are) the duly appointed agent(s) of the petitioner (s), and that all information given here is true and a statement of fact.

Petitioner may assign an agent to present petition to the Commission and Council. The agent must sign the petition in below, and provide address and telephone number

SIGNATURE *John C Boain, DDS*

ADDRESS 1001 Dunn Road Florissant, MO 63031
 STREET CITY STATE ZIP CODE

TELEPHONE NUMBER 314-921-3527
 BUSINESS

I (we) the petitioner (s) do hereby appoint _____ as
 Print name of agent.
 my (our) duly authorized agent to represent me (us) in regard to this petition.

 Petitioner or authorized agent's signature

NOTE: When the petitioner and/or his duly authorized agent appears before the Planning and Zoning Commission and to make a presentation, the same individuals must also appear before the City Council at the Public Hearing to make the presentation and no one else will be permitted to make the presentation to the City Council.

IF DESCRIPTIONS OF PLATS OR SURVEYS ARE INCORRECT, OR IF THE PETITION FORM IS NOT CORRECTLY AND COMPLETELY FILLED OUT, IT WILL BE RETURNED FOR ADDITIONS OR CORRECTIONS AND WILL HAVE TO BE RE-SUBMITTED.

REQUIRED INFORMATION

Please mark an "X" in the appropriate type of operation then fill in applicable section (a), (b) or (c). Corporations are to submit copy of Missouri corporate papers with registration papers.

1) Type of Operation:

Individual _____ Partnership _____ Corporation ✓

(a) If an individual:

- (1) Name and Address _____
- (2) Telephone Number _____
- (3) Business Address _____
- (4) Date started in business _____
- (5) Name in which business is operated if different from (1) _____
- (6) If operating under a fictitious name, provide the name and date registered with the State of Missouri, and a copy of the registration.

(b) If a partnership:

- (1) Names & addresses of all partners _____
- (2) Telephone numbers _____
- (3) Business address _____
- (4) Name under which business is operated _____
- (5) If operating under fictitious name, provide date the name was registered with the State of Missouri, and a copy of the registration.

(c) If a corporation:

- (1) Names & addresses of all partners John C Boain, DDS
- (2) Telephone numbers _____
- (3) Business address 1001 Dunn Road Florissant, Mo 63031
- (4) State of Incorporation & a photocopy of incorporation papers MO
- (5) Date of Incorporation 3/20/2009
- (6) Missouri Corporate Number 43-1119522 CC0194667
- (7) If operating under fictitious name, provide the name and date registered with the State of Missouri, and a copy of registration. _____
- (8) Name in which business is operated John C Boain DDS PC INC
- (9) Copy of latest Missouri Anti-Trust. (annual registration of corporate officers) If the property location is in a strip center, give dimensions of your space under square footage and do not give landscaping information.

Please fill in applicable information requested. If the property is located in a strip center, give the dimensions of your space under square footage and do not give landscaping information.

Name John C Boain DDS PC Inc

Address 1001 Dunn Road Florissant, MO 63031

Property Owner John C Boain DDS

Location of property 1001 Dunn Rd Florissant, MO 63031

Dimensions of property Approx 125' X 193'

Property is presently zoned _____ Requests Rezoning To _____

Proposed Use of Property _____

Type of Sign monument Height 6' 4"

Type of Construction Brick Number Of Stories 1

Square Footage of Building Approx 4800 Number of Curb Cuts 1

Number of Parking Spaces 38 Sidewalk Length 0

Landscaping: No. of Trees 6 Diameter unknown

No. of Shrubs 5 Size unknown

Fence: Type none Length _____ Height _____

PLEASE SUBMIT THE FOLLOWING:

1. Plan or drawing showing zoning of adjoining properties.
2. Plan or drawing showing location of property in relation to major streets and all adjoining properties.
3. Drawing showing measurement of tract and overall area of tract.
4. Plan or drawing showing proposed parking layout, landscaping, parking lighting and trash enclosure.
5. If Special Permit is for a sign show location of sign on plot plan.

**PROVIDE LEGAL DESCRIPTION OF PROPERTY PERTAINING TO THIS
PETITION**

(Close legal description with acreage to the nearest tenth of an acre).

Provide a legal description of the property. If part of a shopping center list address and state part of what shopping center (i.e.: 351 N. Highway 67 part of Florissant Meadows Shopping Center). If property is a single lot, list full written legal description with bearings and distances.

PROVIDE LOCATION MAP SHOWING AREA INVOLVING THIS PETITION

Provide a drawing of a location map showing the nearest major intersection.

OFFICE USE ONLY

Date Application reviewed _____

STAFF REMARKS: _____

Building Commissioner or Staff Signature

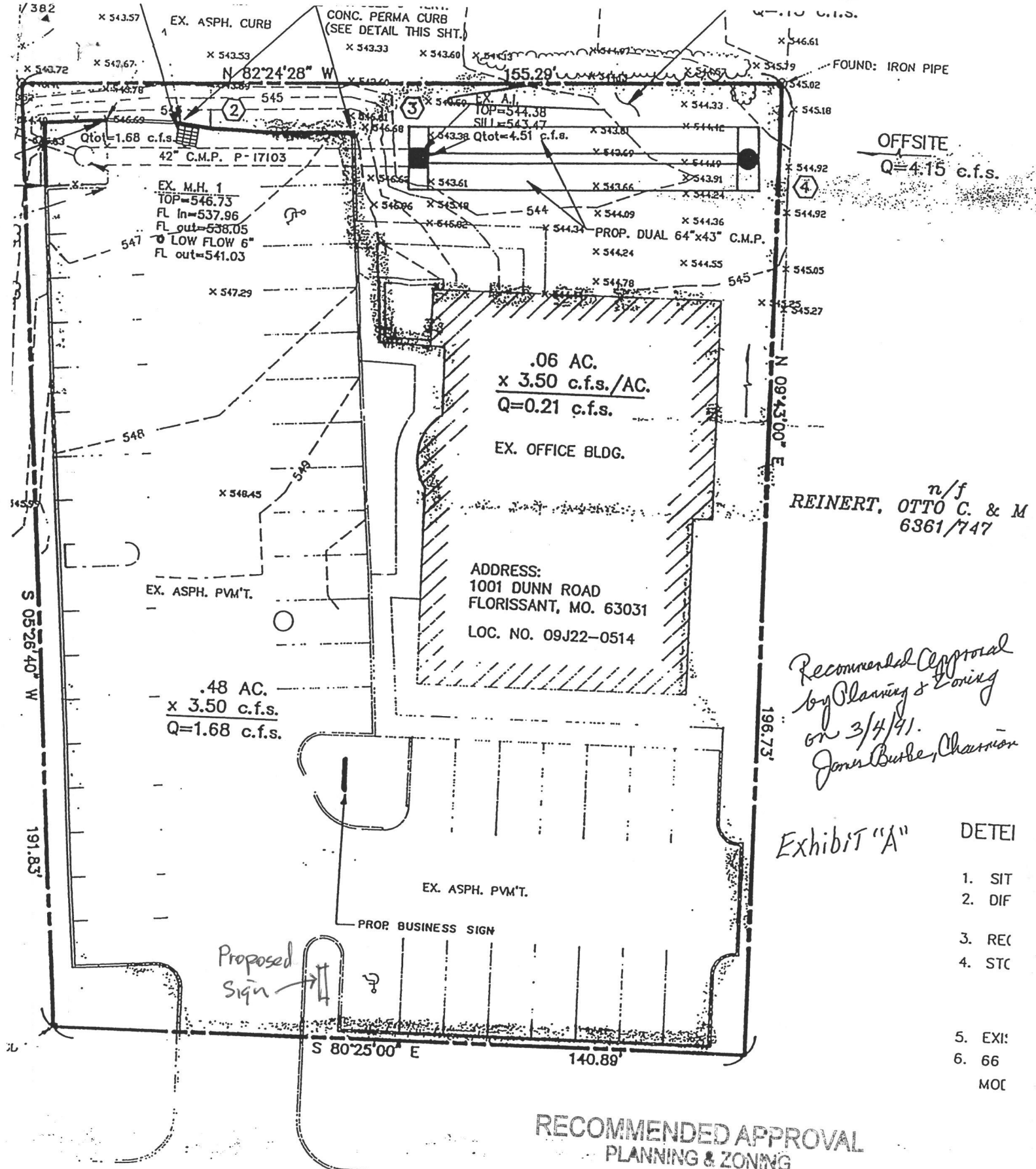

OFFSITE
Q=4.15 c.f.s.

n/f
REINERT, OTTO C. & M
6361/747

*Recommended Approval
by Planning & Zoning
on 3/4/91.
John Burke, Chairman*

Exhibit "A"

- DETEI
1. SIT
 2. DIF
 3. REC
 4. STC
 5. EXI
 6. 66
- MOC

RECOMMENDED APPROVAL
PLANNING & ZONING
CHAIRMAN

SIGN. *Paul [Signature]* DATE: 1/3/2017 7. THE CAL

DUNN ROAD

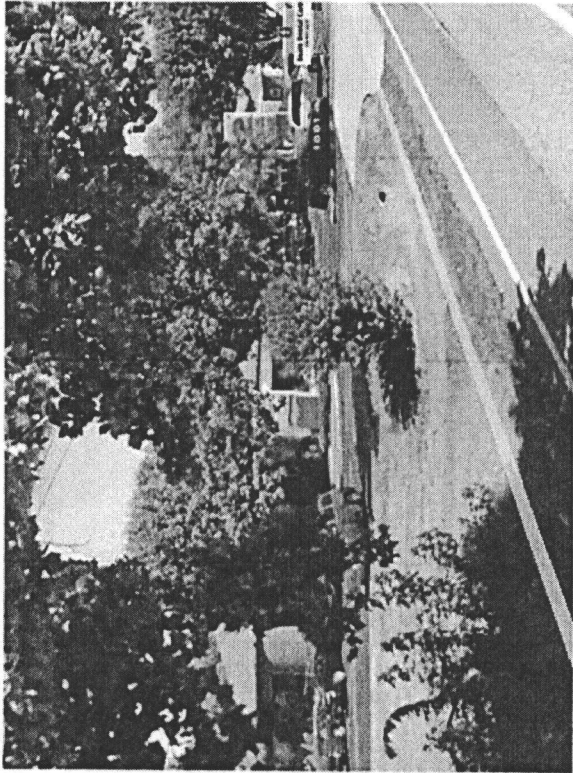

Internally Illuminated Double Sided Monument

Scale: 1/2"=1'-0"

**RECOMMENDED APPROVAL
PLANNING & ZONING**

CHAIRMAN

Paul J. [Signature] DATE: 1/3/2017

SIGN.

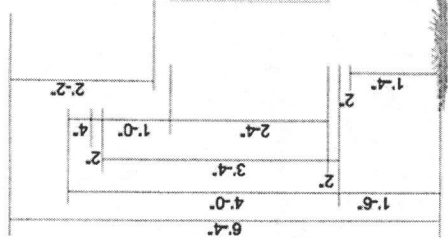
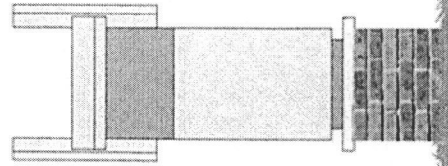
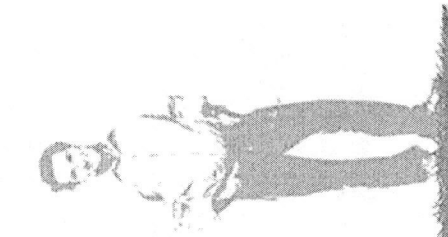
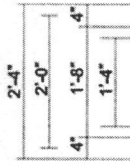

THIS SIGN IS INTENDED TO BE INSTALLED IN ACCORDANCE WITH THE
REQUIREMENTS OF THE ILLINOIS SIGNAGE ACT AND ANY
AND/OR OTHER APPLICABLE LOCAL CODES. THIS INCLUDES PROPER
ANCHORING AND BOLTING OF THE SIGN.



PIRO-SIGNS
ELECTRIC SIGN
FILE NUMBER E24074

Dr. John Boain, 1001 Dunn Road



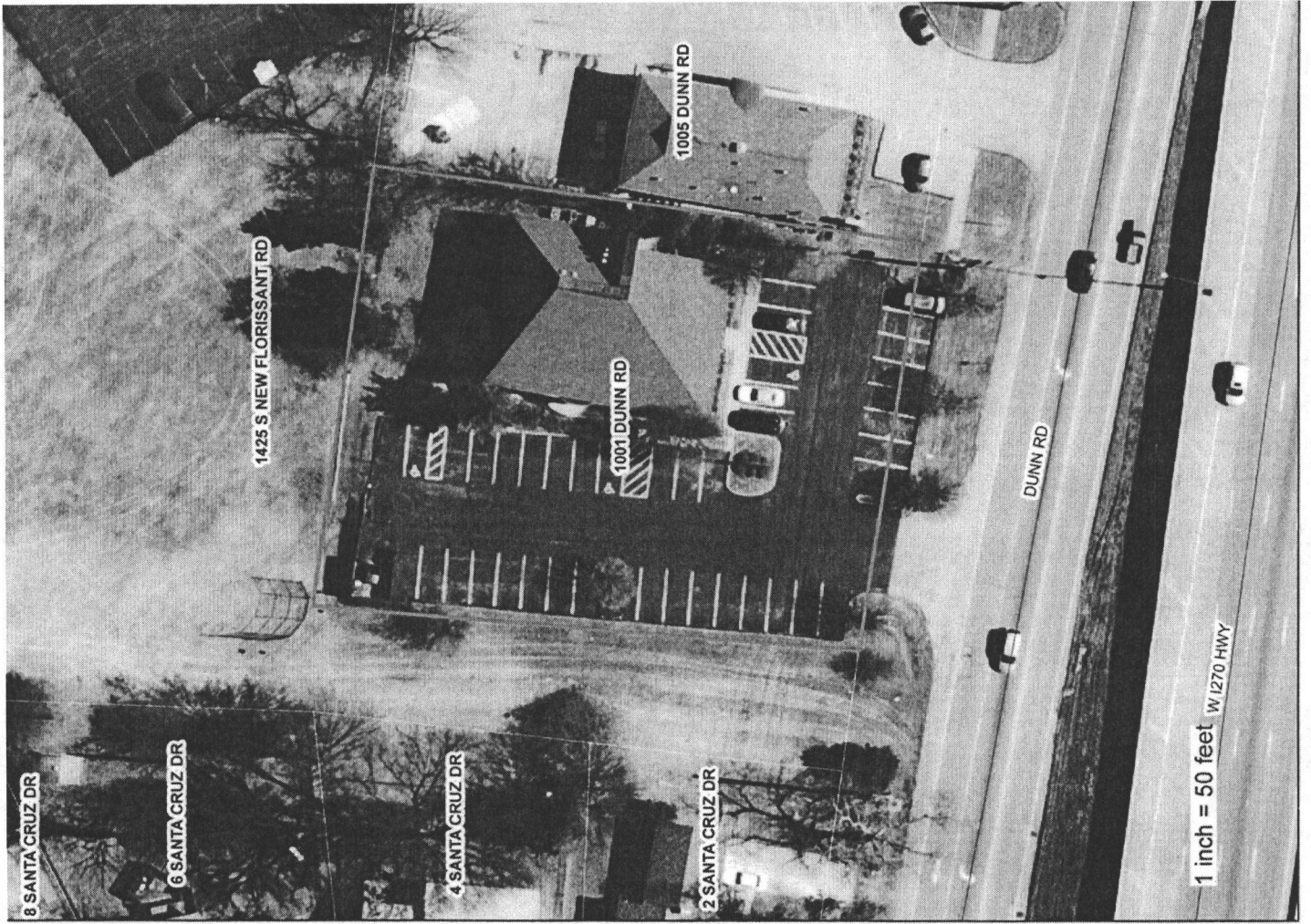

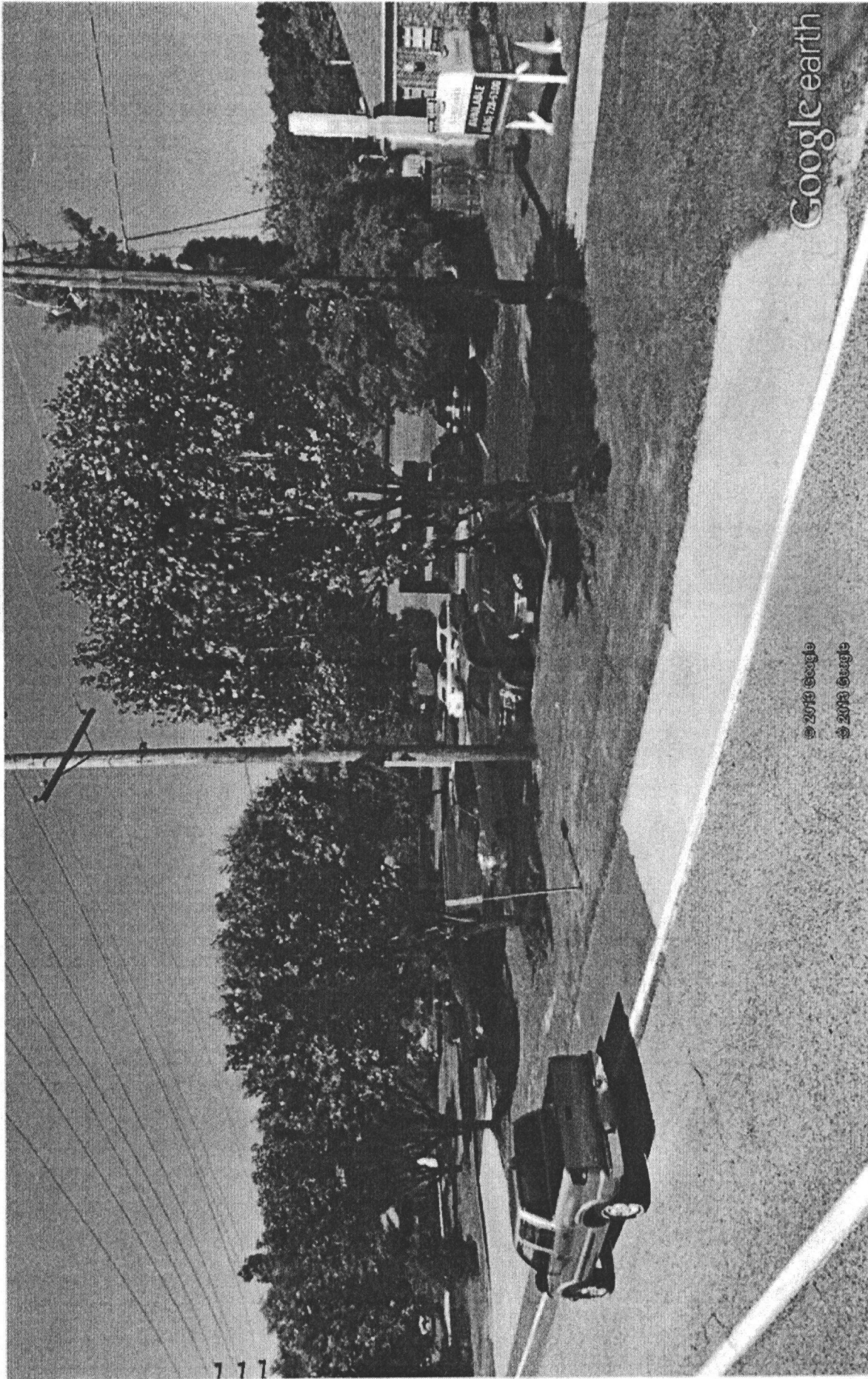

Google earth

© 2019 Google
© 2019 Google

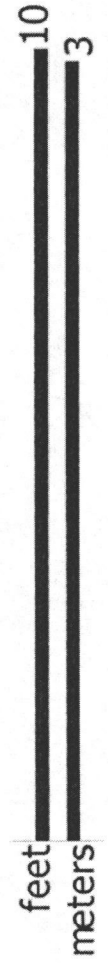

Google earth

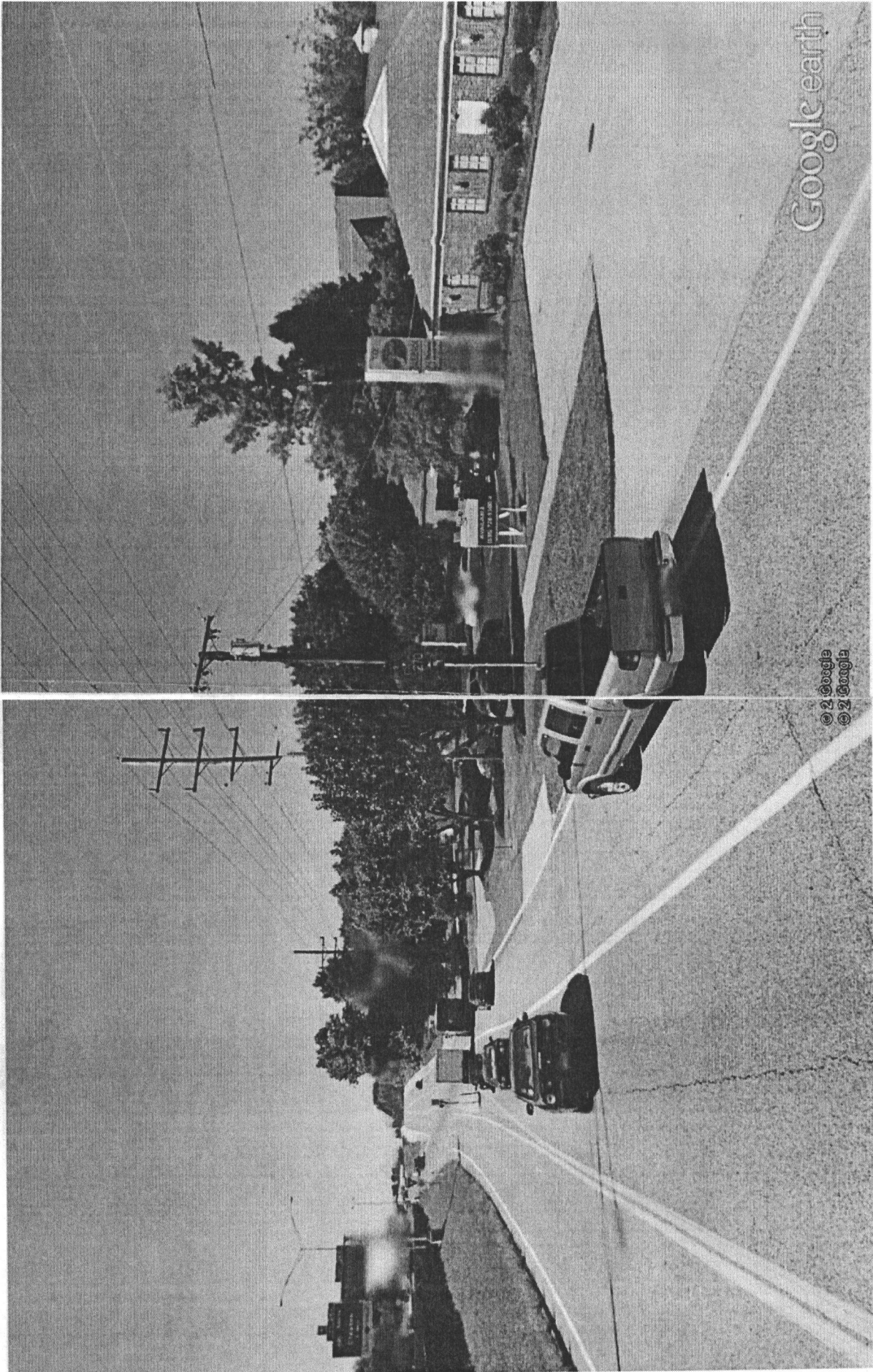

Google earth

© 2002 Google
© 2002 Google

20

6

feet
meters

oogle earth

1

MEMORANDUM

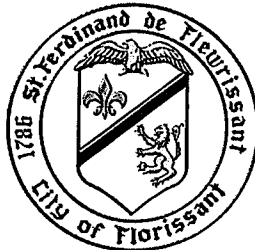

2
3
4
5
6
7
8
9

CITY OF FLORISSANT

"Preserve and improve the health, safety, and welfare of our residents, businesses and the general public in the City of Florissant; while at the same time maintaining property values and improving the quality of life in the City of Florissant."

To: Planning and Zoning Commissioners Date: November 16, 2016
December 20, 2016 rev.

10 From: Philip E. Lum, AIA-Building Commissioner cc: Louis B. Jearls, Jr.- P.E., PWLF
11 Director of Public Works
12 Applicant
13 File
14

15 Subject: Request recommended approval to amend a Special Use, ordinance 4830
16 (as amended by ords. 5071, 5255 and 5259) to locate a ground sign in an
17 'R-4' Zoning District at 1001 Dunn Road, Dr. Boain, DDS.
18

19
20

STAFF REPORT
CASE NUMBER PZ-112116-1

21
22
23

I. PROJECT DESCRIPTION:

24
25 This is a request to amend a Special Use, ordinance 4830 (as amended by ords. 5071,
26 5255 and 5259) to locate a ground sign in an 'R-4' Zoning District.
27

28 **II. SITE CONDITIONS:**

29
30 The existing property at 1001 Dunn Road is a dental practice by Special Use, ordinance
31 no. 4830 (as amended by ords. 5071, 5255 and 5259).
32

33 The existing property is currently occupied by Dr. Boain.
34

35 The subject property has one building. The total area of the building is approximately
36 6835 s.f. and constructed of masonry. The building was originally a blood donation
37 center.
38

39 **III. SURROUNDING PROPERTIES:**

40 The property is surrounded on 2 sides by the church property at 1425 S. New Florissant
41 Road and is also adjacent to 1005 Dunn Road both in the 'R-4' Zoning District.

42
43 **IV. STAFF ANALYSIS:**

44 Because this commercial business was granted a Special Use in an 'R-4' district, staff
45 presumes that the Special Use can continue and can be proposed to be amended. The
46 sign code allows for a ground sign to be proposed in the front yard setback if there is a
47 hardship and not simply for convenience.

48
49 Under the Building Code and definition of a ground sign:

50
51 **SECTION 520.050: GROUND SIGNS**

52 *A. Material. All ground signs for which a permit is required under this Article shall have a surface or facing of*
53 *incombustible material, but combustible structural trim may be used thereon.*

54 *B. Letters, Figures, Etc. All letters, figures, characters or representations in cut-out, irregular form, maintained*
55 *in conjunction with, attached to or superimposed upon any sign, which shall be safely and securely built or attached to*
56 *the sign structure, shall comply with all the requirements of this Article.*

57 *C. Height. It shall be unlawful to erect any ground sign whose total height is greater than twenty-five (25) feet*
58 *above the level of the street upon which the sign faces or above the adjoining ground level if such ground level is above*
59 *the street level; however, such sign or signs may be erected and maintained to a total height of forty (40) feet upon*
60 *approval by a majority of the Planning and Zoning Commission, subject to conditions and restrictions deemed*
61 *appropriate by the Planning and Zoning Commission and as otherwise required by this Article.*

62 *D. Location. No ground sign shall be nearer than two (2) feet to any other sign, building or structure. No*
63 *ground sign shall be nearer the street than the building line established by law. Ground signs are prohibited in*
64 *shopping centers and all existing ground signs in a shopping center shall be removed by July 31, 1973; however, a*
65 *special permit authorizing the location of a ground sign may be issued by the Council if the Council finds that the*
66 *issuance of such permit shall alleviate a hardship and is not simply for the convenience of the applicant, that such*
67 *proposed sign would be consistent with good planning practices, can be maintained in a manner which is visually*
68 *compatible with the use of the property in the surrounding area and other sign structures within the surrounding area*
69 *and is not located in the historic district.*

70 *E. Support. All ground signs shall be securely built, constructed and erected upon posts and standards designed*
71 *by standard engineering practice and shall not be supported and braced by timbers or metal rods.*

72 *F. Treating Of Posts. All posts of wood shall be treated to protect them from moisture by creosoting or other*
73 *approved methods when they rest upon or enter into the ground.*

74 *G. Maintenance. All ground signs and the premises surrounding the sign shall be maintained by the owner*
75 *thereof in a clean, sanitary and inoffensive condition and free and clear of all obnoxious substances, rubbish and*
76 *weeds.*

- 77
78 **1. The application was continued for the applicant to choose a solution to**
79 **improving the visibility of the business. Options available:**
80 **a. Go ahead with the original sign proposal at the SE corner of the lot.**
81 **b. Remove trees in the right-of-way and provide total of 3 frontage trees**
82 **on the property located as recommended by the Commission.**
83 **c. Withdraw the sign proposal, with or without amending frontage**
84 **plantings.**
85 **d. Propose sign on east side or west side of entrance drive.**

86
87 **VI. STAFF RECOMMENDATIONS:**

88 **December 20, 2016 Suggested Motion to recommend approval to locate a ground**
89 **sign:**

90
91 I move to approve the sign presented as located on the property, according to the proposal
92 prepared by the petitioner as described related documents presented **the ground sign**

93 **being located** . Approval is subject to the regulations of the City
94 of Florissant building code, and the following additional requirements:
95

96 **1. GENERAL DEVELOPMENT CONDITIONS.**
97

98 a. Unless, and except to the extent, otherwise specifically provided, the sign
99 shall be effected only in accordance with all ordinances of the City of
100 Florissant.

101 **b. The sign shall be located as follows:**
102

103 **c. The sign shall be limited to the following size:**
104
105

106 **2. PROJECT COMPLETION.**
107

108 Construction shall start within 30 days of the issuance of building permits for
109 the project and shall be installed in accordance of the approved construction
110 plan within 90 days of start of construction.
111

112 (End of suggested motion)

1 INTRODUCED BY COUNCILMAN SCHILDROTH
2 JANUARY 23, 2017

3
4 BILL NO. 9256

ORDINANCE NO.

5
6 **ORDINANCE TO AUTHORIZE AN AMENDMENT TO SPECIAL USE**
7 **PERMIT NO. 7398 TO ALLOW FOR EXTERIOR ALTERATIONS FOR**
8 **THE PROPERTY LOCATED AT 1261 GRAHAM ROAD.**
9

10 WHEREAS, the Florissant Zoning Ordinance authorizes the City Council of the City of
11 Florissant, by Special Use Permit, after public hearing thereon, to permit the location and
12 operation of a restaurant; and

13 WHEREAS, the Florissant City Council has heretofore granted a Special Use Permit to
14 Starbuck Corporation d/b/a Starbucks for the location and operation of a restaurant on the
15 property described in Ordinance No. 7398; and

16 WHEREAS, an application has been filed by Starbucks Corporation for an amendment
17 to the said Special Use Permit heretofore granted under Ordinance No. 7398 to authorize the
18 addition of certain conditions; and

19 WHEREAS, the Planning and Zoning Commission of the City of Florissant at their
20 meeting of January 3, 2017 has recommended that the said Special Use Permit be amended; and

21 WHEREAS, due notice of public hearing no. 17-01-003 on said application to be held on
22 the 23rd day of January, 2017 at 7:30 P.M. by the Council of the City of Florissant was duly
23 published, held and concluded; and

24 WHEREAS, the Council, following said public hearing, and after due and careful
25 consideration, has concluded that the granting of an amendment to the Special Use Permit
26 authorized by Ordinance No. 7398, as hereinafter provided would be in the best interest of the
27 City of Florissant.

28 NOW, THEREFORE, BE IT ORDAINED BY THE COUNCIL OF THE CITY OF
29 FLORISSANT, ST. LOUIS COUNTY, MISSOURI, AS FOLLOWS:

30
31 Section 1: The Special Use Permit heretofore granted to Starbucks
32 Corporation under Ordinance No. 7398 in a B-3 Zoning District is hereby amended to
33 allow a remodeling of the exterior, according to the proposal prepared by the petitioner as
34 described in related documents presented and according to the attached drawings as
35 prepared by Starbucks Coffee Company and dated 12/14/16. Approval is subject to the

36 regulations of these ordinances of the City of Florissant, and the following additional
37 requirements:

38 1. GENERAL DEVELOPMENT CONDITIONS.

39 a. Unless, and except to the extent, otherwise specifically provided, in
40 Ord No. 7398, development shall be effected only in accordance with
41 all ordinances of the City of Florissant.

42 2. PROJECT COMPLETION.

43 a. Construction shall start within 90 days of the issuance of building
44 permits for the project and shall be developed in accordance of the
45 approved final development plan within 180 days of start of
46 construction.
47

48 Section 2: Said Special Permit shall be conditioned on and shall remain in full force and
49 effect so long as the conditions set out in Ordinance no. 7398, as now amended, are adhered to.

50 Section 3: This ordinance shall become in force and effect immediately upon its passage
51 and approval.

52
53 Adopted this ____ day of _____, 2017.

54
55
56 _____
57 Jackie Pagano
58 President of the Council
59 City of Florissant
60

61
62 Approved this ____ day of _____, 2012.

63
64
65 _____
66 Thomas P. Schneider
67 Mayor, City of Florissant
68

69 ATTEST:

70
71
72 _____
73 Karen Goodwin, MMC/MRCC
74 City Clerk

CITY OF FLORISSANT

Public Hearing



In accordance with 405.310 of the Florissant Zoning Code a Public Hearing will be held by the City Council of Florissant, MO. in the Council Chambers, 955 Rue St. Francois, on Monday, January 23, 2017 at 7:30 P.M. on the following proposition:

To authorize an amendment to Special Use Permit No. 7398, to allow for exterior alterations for the property located at 1261 Graham Road (legal description to govern). Citizens will have an opportunity to be heard. Anyone with special needs should contact the City Clerk at least 5 days before said public hearing by calling 839-7630 or TDD 839-5142.

CITY OF FLORISSANT, Karen Goodwin, MMC City Clerk

FLORISSANT PLANNING & ZONING COMMISSION APPLICATION

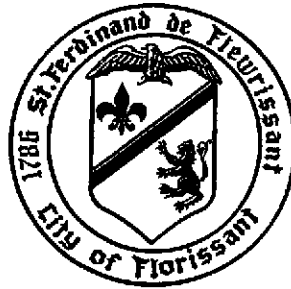

City Of Florissant – Public Works 314-839-7648

"Preserve and improve the health, safety, and welfare of our residents, businesses and the general public in the City of Florissant; while at the same time maintaining property values and improving the quality of life in the City of Florissant."

Application is hereby made to the Building Commissioner, Department of Public Works at the City of Florissant, Missouri, to appear before the Planning & Zoning Commission.

Please Print neatly or Type the Following Information:

Property Address: 1261 Graham Rd, Florissant MO 63031

Property Owners Name: Sherman Partners LLC Phone/email: 615-366-1098/cvaughn@cherryandassociates.com

Property Owners Address: 505 Westview Ave, Nashville TN 37205

Business Owners Name: Starbucks Corporation Phone/email: 206-318-1575

Business Owners Address: 2401 Utah Ave South, MS Stop: S-SD 10, Seattle WA 98134

DBA (Doing Business As) Starbucks

Authorized Agents Name: Richard Avery, acting on behalf of Lee Weintraub Co. Name: Zimmerman Weintraub Associates LLC (Authorized Agent to Appear Before The Commission)

Agents Address: 813 W Randolph St, Chicago IL 60607 Phone/email: 312-879-9636 x205

Request Amendment to existing Special Use Permit 7398 - alterations to a sit-down, drive-through, carry-out coffee shop

Proposed changes to improve overall appearance of building include: exterior paint color change, cladding material change, signage update, and parapet-height change to hide existing RTUs.

State complete request (print or type only).

IF A TRAFFIC STUDY IS REQUIRED FOR CERTAIN DEVELOPMENTS AND USES THE COST OF THE TRAFFIC STUDY SHALL BE PAID BY THE APPLICANT. PLEASE SUBMIT FOLDED PLANS

Applicant's Signature

15 Dec. 2016 Date

Received by: [Signature] Receipt # 597877 OFFICE USE ONLY Amount Paid: 125 Date: 12/20/16

STAFF REMARKS:

DATE APPLICATION REVIEWED:

COMMISSION ACTION TAKEN:

SIGNATURE OF STAFF WHO REVIEWED APPLICATION Planning & Zoning Application Page 1 of 1 - Revised 7/15/15

RECOMMENDED APPROVAL PLANNING & ZONING CHAIRMAN

SIGN. [Signature] DATE: 1/3/2017

**SPECIAL USE PERMIT APPLICATION
TO THE CITY OF FLORISSANT
PLANNING AND ZONING COMMISSION**

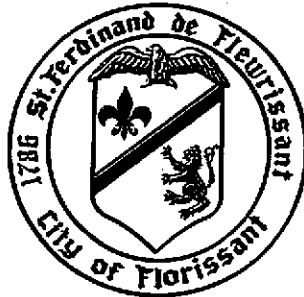

**City Of Florissant – Public Works
314-839-7648**

"Preserve and improve the health, safety, and welfare of our residents, businesses and the general public in the City of Florissant; while at the same time maintaining property values and improving the quality of life in the City of Florissant."

PLANNING & ZONING ACTION

Council Ward 5 Zoning B-3

RECOMMENDED APPROVAL
PLANNING & ZONING
CHAIRMAN

Initial Date Petitioner Filed _____
Building Commissioner to complete
ward, zone & date filed

[Signature] DATE: 1/3/2017

SPECIAL PERMIT FOR operation of a sit-down, carry-out and drive-through coffee house with food

Statement of what permit is being sought. (i.e., special permit for operation of a restaurant).

AMEND SPECIAL PERMIT # 7398 TO ALLOW FOR finish changes to masonry paint, cladding material and parapet height
ordinance # _____ Statement of what the amendment is for.

LOCATION 1261 Graham Rd, Florissant MO 63031

Address of property.

1) Comes Now Starbucks Corporation

Enter name of petitioner. If a corporation, state as such. If applicable include DBA (Doing Business As)

and states to the Planning and Zoning Commission that he (she) (they) has (have) the following legal interest in the tract of land located in the City of Florissant, State of Missouri, as described on page 3 of this petition.

Legal interest in the Property) Lease

State legal interest in the property. (i.e., owner of property, lease).
Submit copy of deed or lease or letter of authorization from owner to seek a special use.

2) The petitioner(s) further state(s) that the property herein described is presently being used for operation of a sit-down, carry-out and drive-through coffee house with food and that the deed restrictions for the property do not prohibit the use which would be authorized by said Permit.

3) The petitioner(s) further states (s) that they (he) (she) are submitting a detailed site plan of the proposed or existing development showing location and use of all structures, off-street parking, and all other information required by the Zoning Ordinance or determined necessary by the Building Commissioner.

- 4) The petitioner(s) further state(s) that (he) (she) (they) shall comply with all of the requirements of the City of Florissant, including setback lines and off- street parking.
- 5) The petitioner (s) further (represent (s) and warrants (s) that they (he) (she) has (have) not made any arrangement to pay any commission gratuity or consideration, directly or indirectly to any official, employee or appointee of the City of Florissant, with respect to this application.
- 6) The petitioner(s) further state (s) that the Special Use Permit is sought for the following purposes, and no other, as listed in detail, all activities sought to be covered by the permit (i.e.; operation of a business, approval of building and/or site plans (preliminary and / or final), plan approval for signage, etc.):
- 7) The petitioner (s) state (s) the following factors and reason to justify the permit:
(If more space is needed, separate sheets maybe attached)

Lee Weintraub / 312-879-9636/lweintraub@zwalink.com
 PRINT NAME SIGNATURE email and phone
 FOR Zimmerman Weintraub Associates LLC acting on behalf of Starbucks Corporation
 (company, corporation, partnership)

Print and sign application. If applicant is a corporation or partnership signature must be a CORPORATE OFFICER or a PARTNER. NOTE: Corporate officer is an individual named in corporate papers.

8) I (we) hereby certify that, as applicant (circle one of the following):

1. I (we) have a legal interest in the herein above described property.

2. I am (we are) the duly appointed agent(s) of the petitioner (s), and that all information given here is true and a statement of fact.

Permission granted by the Petitioner assigning an agent (i.e. Architect) to present this petition in their behalf, to the Commission and/or Council. The petitioner must sign below, and provide contact information:

PRESENTOR SIGNATURE Richard Avery Digitally signed by Richard Avery
 Date: 2016.12.15 12:24:52 -06'00'
 ADDRESS 813 W Randolph St, Chicago IL 60607
 STREET CITY STATE ZIP CODE
 TELEPHONE / EMAIL 312-879-9636 x205 / ravery@zwalink.com
 BUSINESS

I (we) the petitioner (s) do hereby appoint Zimmerman Weintraub Associates as
 Print name of agent.
 my (our) duly authorized agent to represent me (us) in regard to this petition.

 Signature of Petitioner authorizing an agent

NOTE: When the petitioner and/or his duly authorized agent appears before the Planning and Zoning Commission and to make a presentation, the same individuals must also appear before the City Council at the Public Hearing to make the presentation and no one else will be permitted to make the presentation to the City Council without authorized approval.

IF DESCRIPTIONS, PLATS OR SURVEYS ARE INACCURATE, OR IF THE PETITION APPLICATION IS NOT CORRECT OR COMPLETE, IT WILL BE RETURNED FOR ADDITIONS OR CORRECTIONS.

REQUIRED INFORMATION

Please mark an "X" in the appropriate type of operation, then fill in applicable section (a), (b) or (c).
Corporations are to submit copy of Missouri corporate papers with registration papers.

1) Type of Operation: Individual _____ Partnership _____ Corporation X

(a) If an individual:

(1) Name and Address _____

(2) Telephone Number _____

(3) Business Address _____

(4) Date started in business _____

(5) Name in which business is operated if different from (1) _____

(6) If operating under a fictitious name, provide the name and date registered with the State of Missouri, and a copy of the registration.

(b) If a partnership:

(1) Names & addresses of all partners _____

(2) Telephone numbers _____

(3) Business address _____

(4) Name under which business is operated _____

(5) If operating under fictitious name, provide date the name was registered with the State of Missouri, and a copy of the registration.

(c) If a corporation:

(1) Names & addresses of all partners Please see attached Annual Registration Report

(2) Telephone numbers Please see attached Annual Registration Report

(3) Business address 221 Bolivar Street, Jefferson City MO 65101

(4) State of Incorporation & a photocopy of incorporation papers Missouri

(5) Date of Incorporation Please see attached Annual Registration Report

(6) Missouri Corporate Number Please see attached Annual Registration Report

(7) If operating under fictitious name, provide the name and date registered with the State of Missouri, and a copy of registration. _____

(8) Name in which business is operated Starbucks

(9) Copy of latest Missouri Anti-Trust. (annual registration of corporate officers) If the property location is in a strip center, give dimensions of your space under square footage and do not give landscaping Information.

Please fill in applicable information requested. If the property is located in a shopping center, provide the dimensions of the tenant space under square footage and landscaping information may not be required.

Name Starbucks

Address 1261 Graham Rd, Florissant MO 63031

Property Owner Sherman Partners LLC

Location of property West side of Graham Rd just east of Dunn Rd.

Dimensions of property 265'x154' per existing site plan

Property is presently zoned B3 Requests Rezoning To _____

Proposed Use of Property operation of a sit-down, carry-out and drive-through coffee house with food

Type of Sign updated signs on existing footings Height _____

Type of Construction IIB Number Of Stories 1

Square Footage of Building 3354 Number of Curb Cuts 2

Number of Parking Spaces 56 existing to remain Sidewalk Length 163'

Landscaping: No. of Trees existing to remain Diameter _____

No. of Shrubs _____ Size _____

Fence: Type N/A Length _____ Height _____

PLEASE SUBMIT THE FOLLOWING INFORMATION ON PLANS OR DRAWINGS:

1. Zoning of adjoining properties.
2. Show location of property in relation to major streets and all adjoining properties.
3. Show measurement of tract and overall area of tract.
4. Proposed parking layout and count, parking lighting.
5. Landscaping and trash screening.
5. Location, sizes and elevations of signage.

PROVIDE LEGAL DESCRIPTION OF PROPERTY PERTAINING TO THIS PETITION

(Close legal description with acreage to the nearest tenth of an acre).

Provide a legal description of the property. If part of a shopping center, list address and show part of what shopping center (i.e.: 351 N. Highway 67 part of Florissant Meadows Shopping Center). If property is a single lot, list full written legal description with metes and bounds bearings and dimensions.

PLEASE SEE ATTACHED
LEGAL DESCRIPTION, p.60

PROVIDE LOCATION MAP SHOWING AREA INVOLVING THIS PETITION

Provide a drawing of a location map showing the nearest major intersection.

PLEASE SEE ATTACHED
LOCATION MAP, p.61

OFFICE USE ONLY

Date Application reviewed _____

STAFF REMARKS: _____

Building Commissioner or Staff Signature

1 INTRODUCED BY COUNCILMAN SCHILDROTH
2 APRIL 23, 2007

3
4
5 BILL NO. 8311

ORDINANCE NO. 7398

6
7 AN ORDINANCE GRANTING A SPECIAL USE PERMIT TO
8 STARBUCKS COFFEE COMPANY D/B/A STARBUCK'S TO ALLOW
9 FOR THE OPERATION OF A SIT-DOWN, CARRY-OUT AND DRIVE-
10 THROUGH COFFEE HOUSE WITH FOOD FOR THE PROPERTY
11 LOCATED AT 1261 GRAHAM ROAD.

12
13 WHEREAS, the Florissant Zoning Ordinance authorizes the City Council of the City of
14 Florissant, by Special Use Permit, after public hearing thereon, to permit the operation of a
15 coffee house; and

16 WHEREAS, an application has been filed by Starbucks Coffee Company for the
17 operation of a sit-down, carry-out and drive-through coffee house with food located at 1261
18 Graham Road; and

19 WHEREAS, the Planning and Zoning Commission of the City of Florissant, at their
20 meeting of April 2nd, 2007 has recommended that the said Special Use Permit be granted with
21 certain conditions; and

22 WHEREAS, due notice of a public hearing on said application to be held on the April 23,
23 2007 at 8:00 P.M. by the Council of the City of Florissant was duly published, held and
24 concluded; and

25 WHEREAS, the Council, following said public hearing, and after due and careful
26 consideration, has concluded that the granting of the Special Use Permit as hereinafter provided
27 would be in the best interest of the City of Florissant.

28 NOW, THEREFORE, BE IT ORDAINED BY THE COUNCIL OF THE CITY OF
29 FLORISSANT, ST. LOUIS COUNTY, MISSOURI, AS FOLLOWS:

30
31 Section 1: A Special Use Permit is hereby granted to Starbucks Coffee Company d/b/a
32 Starbuck's and renovations of the property shall be in accordance with the plans submitted and
33 dated 1/25/07:

34 Section 2: Said Permit herein authorized shall remain in full force and effect and subject
35 to all of the ordinances of the City of Florissant.

36 Section 3: When the named permittee discontinues the operation of said business, the
37 Special Use Permit herein granted shall no longer be in force and effect.

38 Section 4: This ordinance shall become in force and effect immediately upon its passage
39 and approval.

40

41 Adopted this 14 day of May, 2007.

42

43

44

45

46

47

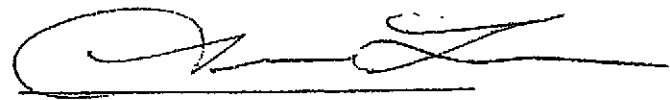

Tim Lee
President of the Council
City of Florissant

48

49

Approved this 15 day of May, 2007.

50

51

52

53

54

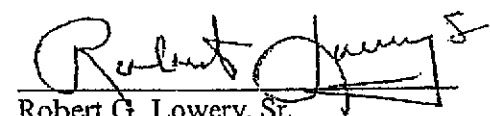

Robert G. Lowery, Sr.
Mayor, City of Florissant

55

56

57

ATTEST:

58

59

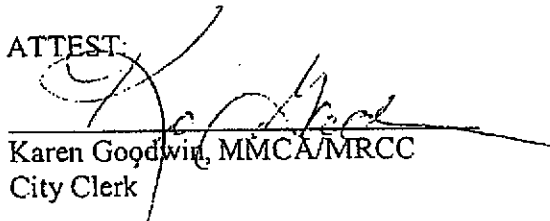
Karen Goodwin, MMCA/MRCC
City Clerk

60

61

62

SIGNAGE SCHEDULE

SIGNAGE SCHEDULE

NO.	DESCRIPTION	QUANTITY	UNIT	DATE	STATUS	REMARKS
001	STARBUCKS COFFEE SIGNAGE	1	SIGN			
002	STARBUCKS COFFEE SIGNAGE	1	SIGN			
003	STARBUCKS COFFEE SIGNAGE	1	SIGN			
004	STARBUCKS COFFEE SIGNAGE	1	SIGN			
005	STARBUCKS COFFEE SIGNAGE	1	SIGN			
006	STARBUCKS COFFEE SIGNAGE	1	SIGN			
007	STARBUCKS COFFEE SIGNAGE	1	SIGN			
008	STARBUCKS COFFEE SIGNAGE	1	SIGN			
009	STARBUCKS COFFEE SIGNAGE	1	SIGN			
010	STARBUCKS COFFEE SIGNAGE	1	SIGN			
011	STARBUCKS COFFEE SIGNAGE	1	SIGN			
012	STARBUCKS COFFEE SIGNAGE	1	SIGN			
013	STARBUCKS COFFEE SIGNAGE	1	SIGN			
014	STARBUCKS COFFEE SIGNAGE	1	SIGN			
015	STARBUCKS COFFEE SIGNAGE	1	SIGN			
016	STARBUCKS COFFEE SIGNAGE	1	SIGN			
017	STARBUCKS COFFEE SIGNAGE	1	SIGN			
018	STARBUCKS COFFEE SIGNAGE	1	SIGN			
019	STARBUCKS COFFEE SIGNAGE	1	SIGN			
020	STARBUCKS COFFEE SIGNAGE	1	SIGN			

NOTES:

1. ALL SIGNAGE SHALL BE INSTALLED IN ACCORDANCE WITH THE SIGNAGE SCHEDULE AND THE NOTES THEREON.

2. THE SIGNAGE SHALL BE INSTALLED IN ACCORDANCE WITH THE SIGNAGE SCHEDULE AND THE NOTES THEREON.

3. THE SIGNAGE SHALL BE INSTALLED IN ACCORDANCE WITH THE SIGNAGE SCHEDULE AND THE NOTES THEREON.

4. THE SIGNAGE SHALL BE INSTALLED IN ACCORDANCE WITH THE SIGNAGE SCHEDULE AND THE NOTES THEREON.

5. THE SIGNAGE SHALL BE INSTALLED IN ACCORDANCE WITH THE SIGNAGE SCHEDULE AND THE NOTES THEREON.

6. THE SIGNAGE SHALL BE INSTALLED IN ACCORDANCE WITH THE SIGNAGE SCHEDULE AND THE NOTES THEREON.

7. THE SIGNAGE SHALL BE INSTALLED IN ACCORDANCE WITH THE SIGNAGE SCHEDULE AND THE NOTES THEREON.

8. THE SIGNAGE SHALL BE INSTALLED IN ACCORDANCE WITH THE SIGNAGE SCHEDULE AND THE NOTES THEREON.

9. THE SIGNAGE SHALL BE INSTALLED IN ACCORDANCE WITH THE SIGNAGE SCHEDULE AND THE NOTES THEREON.

10. THE SIGNAGE SHALL BE INSTALLED IN ACCORDANCE WITH THE SIGNAGE SCHEDULE AND THE NOTES THEREON.

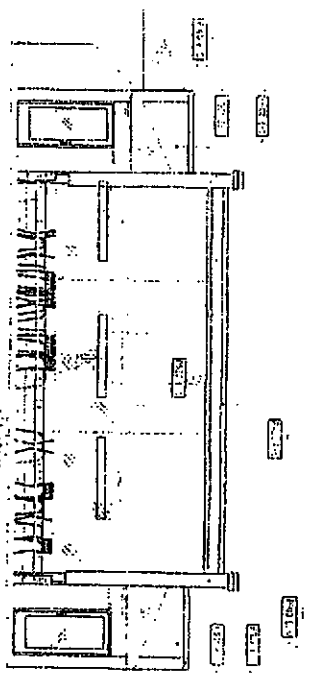

EAST ELEVATION

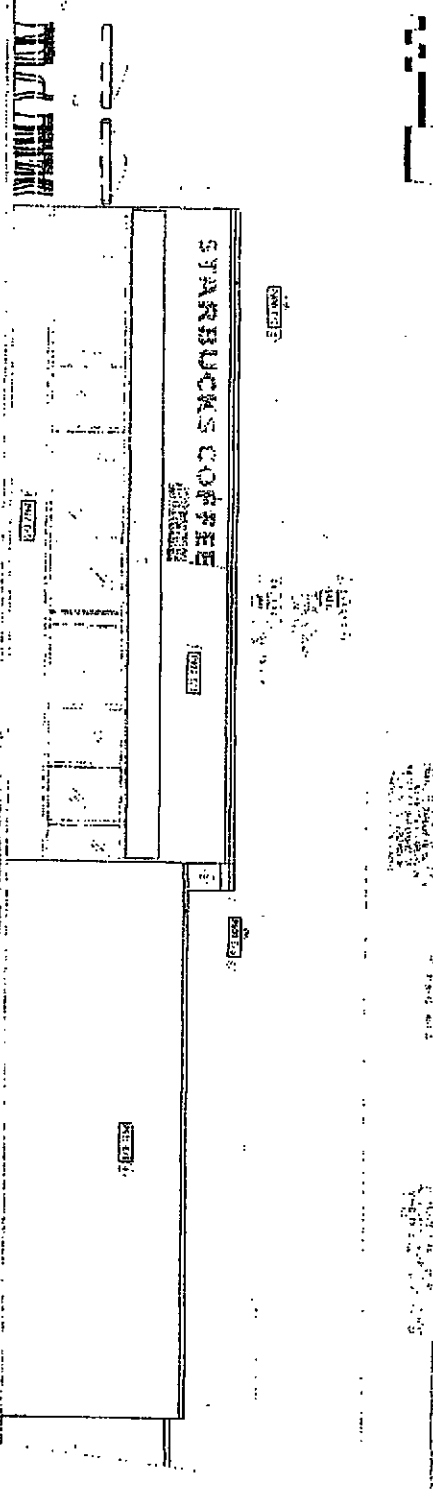

NORTH ELEVATION



STARBUCKS COFFEE COMPANY

STARBUCKS COFFEE
 GRAHAM & I-270
 1261 GRAHAM ROAD
 FLORISSANT, MO 63031
 ST LOUIS

PROJECT # 38195-001
 STORE # 13511
 DESIGNER: JIM
 DATE: 10/13/03
 CHECKED: DM
 DRAWN: DM

STARBUCKS COFFEE COMPANY
 EXTERIOR ELEVATIONS
 SHEET NUMBER A1.0R

SIGNAGE SCHEDULE

NO.	DESCRIPTION	QUANTITY	UNIT	PRICE	TOTAL
1	STARBUCKS COFFEE SIGNAGE	1	SQ. FT.	100.00	100.00
2	STARBUCKS COFFEE SIGNAGE	1	SQ. FT.	100.00	100.00
3	STARBUCKS COFFEE SIGNAGE	1	SQ. FT.	100.00	100.00
4	STARBUCKS COFFEE SIGNAGE	1	SQ. FT.	100.00	100.00
5	STARBUCKS COFFEE SIGNAGE	1	SQ. FT.	100.00	100.00
6	STARBUCKS COFFEE SIGNAGE	1	SQ. FT.	100.00	100.00
7	STARBUCKS COFFEE SIGNAGE	1	SQ. FT.	100.00	100.00
8	STARBUCKS COFFEE SIGNAGE	1	SQ. FT.	100.00	100.00
9	STARBUCKS COFFEE SIGNAGE	1	SQ. FT.	100.00	100.00
10	STARBUCKS COFFEE SIGNAGE	1	SQ. FT.	100.00	100.00

NOTES:

1. ALL SIGNAGE SHALL BE INSTALLED IN ACCORDANCE WITH THE CITY OF ST. LOUIS SIGNAGE ORDINANCES AND THE ILLINOIS SIGNAGE ACT.

2. THE CONTRACTOR SHALL BE RESPONSIBLE FOR OBTAINING ALL NECESSARY PERMITS AND APPROVALS FROM THE CITY OF ST. LOUIS.

3. THE CONTRACTOR SHALL BE RESPONSIBLE FOR THE PROTECTION OF ALL EXISTING UTILITIES AND STRUCTURES.

4. THE CONTRACTOR SHALL BE RESPONSIBLE FOR THE PROTECTION OF ALL EXISTING SIGNAGE.

5. THE CONTRACTOR SHALL BE RESPONSIBLE FOR THE PROTECTION OF ALL EXISTING LANDSCAPE.

6. THE CONTRACTOR SHALL BE RESPONSIBLE FOR THE PROTECTION OF ALL EXISTING TREES.

7. THE CONTRACTOR SHALL BE RESPONSIBLE FOR THE PROTECTION OF ALL EXISTING CURBS AND SIDEWALKS.

8. THE CONTRACTOR SHALL BE RESPONSIBLE FOR THE PROTECTION OF ALL EXISTING DRIVEWAYS.

9. THE CONTRACTOR SHALL BE RESPONSIBLE FOR THE PROTECTION OF ALL EXISTING FENCES.

10. THE CONTRACTOR SHALL BE RESPONSIBLE FOR THE PROTECTION OF ALL EXISTING LIGHT FIXTURES.

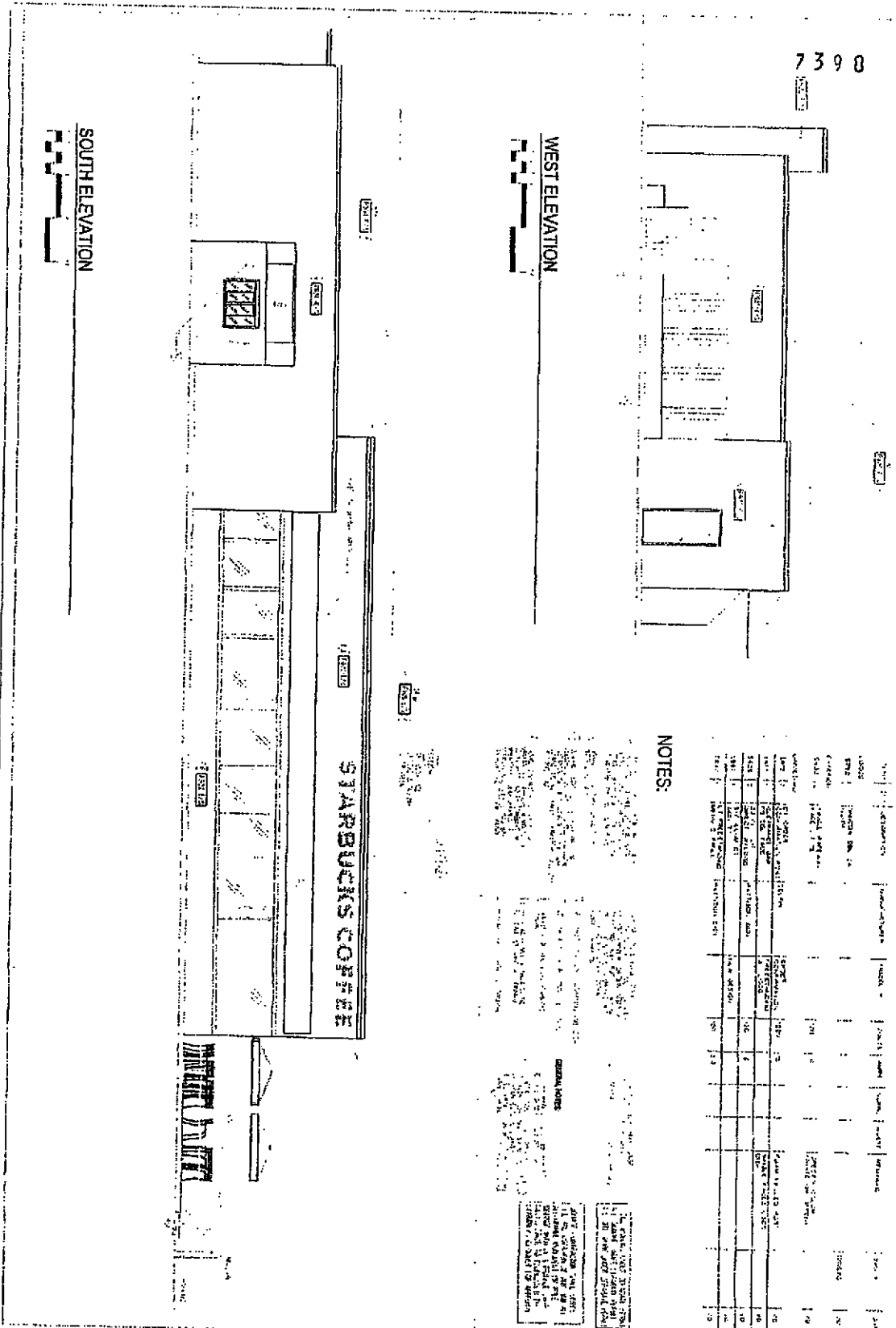

STARBUCKS COFFEE
GRAHAM & I-270
 1261 GRAHAM ROAD
 FLORISSANT, MD 63031
 ST LOUIS

PROJECT: 15511
 DRAWING: 38175E-011
 DATE: 08/14/13
 DESIGNED BY: [Name]
 CHECKED BY: [Name]
 APPROVED BY: [Name]

SCALE: 1/8" = 1'-0"
 SHEET NUMBER: A1.1R

STARBUCKS COFFEE COMPANY
 2000 ROCKAWAY DRIVE
 ST. LOUIS, MO 63108
 (314) 431-1000
 WWW.STARBUCKS.COM

NOTES:

STARBUCKS
COFFEE COMPANY
1401 W. HANNA, SUITE
1000
ST. LOUIS, MO 63104

ARCHITECT OF RECORD
ARCHITECT
1801 OLIVE ROAD, SUITE 200
ST. LOUIS, MO 63104

REV DATE BY DESCRIPTION

STARBUCKS COFFEE
GRAHAM & I-270
1261 GRAHAM ROAD
FLORISSANT, MO 63031
ST LOUIS

DATE: 11/11/03
DRAWN BY: [illegible]
CHECKED BY: [illegible]
DATE: 11/11/03

PROJECT # 13511
PROJECT # 03136-007
CONTRACT # 03136-007
SHEET TITLE
SHEET NO. 1
DATE: 11/11/03
DRAWN BY: [illegible]
CHECKED BY: [illegible]
DATE: 11/11/03

SCALE: 1/8" = 1'-0"
DO NOT SCALE DIMENSIONS
SHEET NUMBER
C1.0

NO.	DATE	BY	DESCRIPTION
1	11/11/03	[illegible]	ISSUED FOR PERMITS
2	11/11/03	[illegible]	ISSUED FOR PERMITS
3	11/11/03	[illegible]	ISSUED FOR PERMITS
4	11/11/03	[illegible]	ISSUED FOR PERMITS
5	11/11/03	[illegible]	ISSUED FOR PERMITS
6	11/11/03	[illegible]	ISSUED FOR PERMITS
7	11/11/03	[illegible]	ISSUED FOR PERMITS
8	11/11/03	[illegible]	ISSUED FOR PERMITS
9	11/11/03	[illegible]	ISSUED FOR PERMITS
10	11/11/03	[illegible]	ISSUED FOR PERMITS

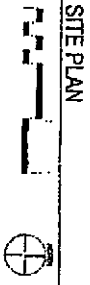

SITE PLAN

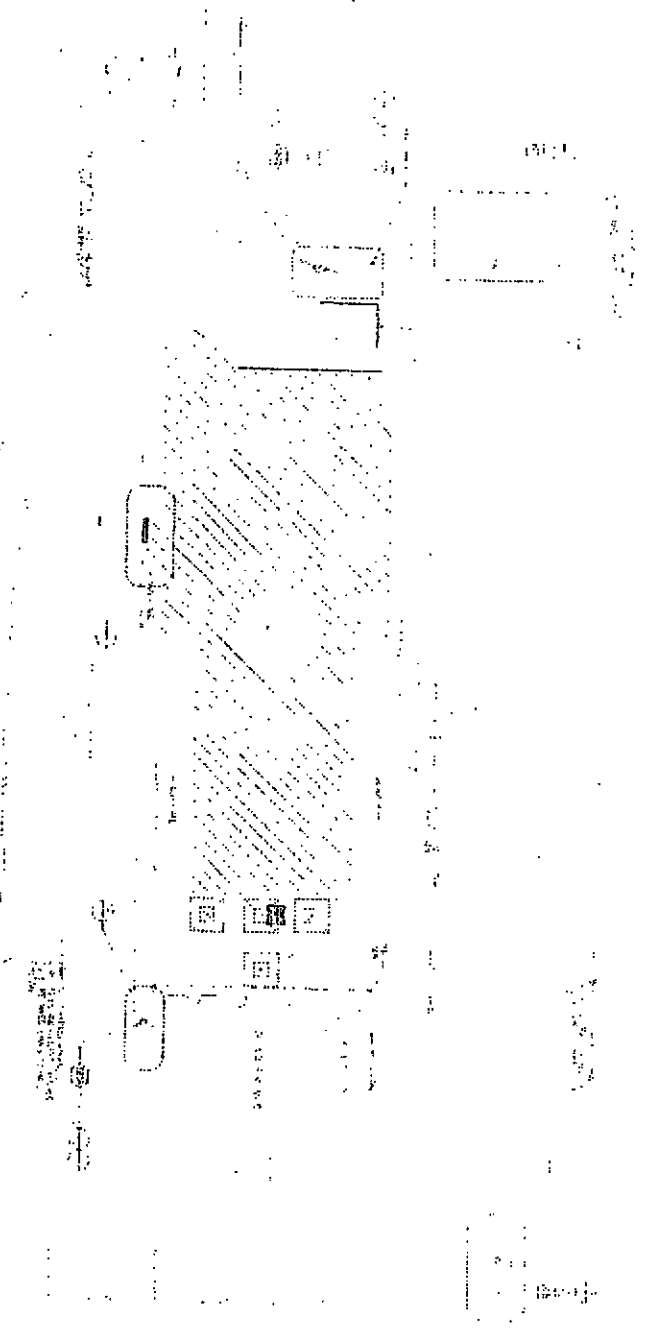

2198

PLANT SCHEDULE:



PLANT	QUANTITY



PLANT	QUANTITY



PLANT	QUANTITY

PLANT	QUANTITY

LANDSCAPING PLAN



Scale: 1" = 10'-0"

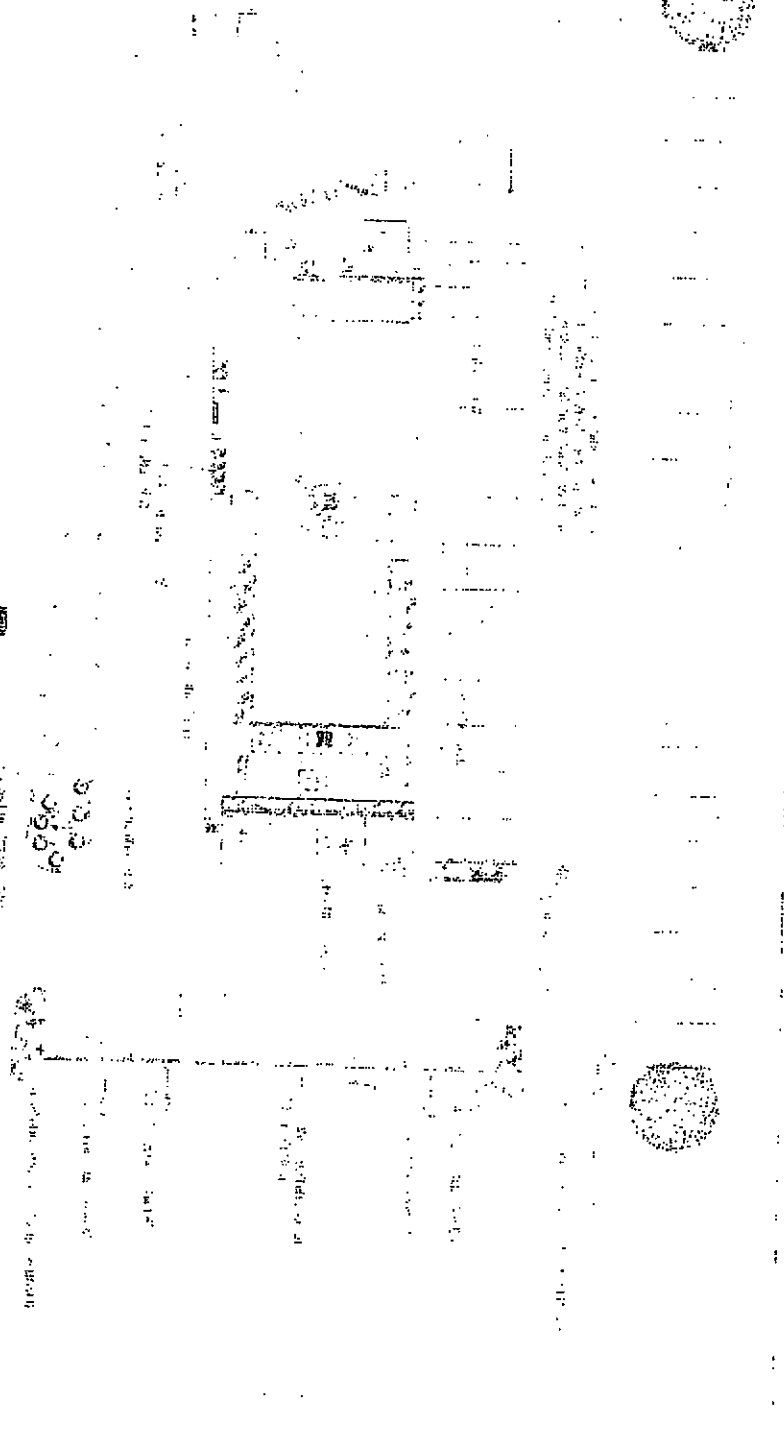

STARBUCKS COFFEE COMPANY 2415 JEFFERSON AVENUE ST. LOUIS, MO 63103 TEL: (314) 433-1000	PROJECT: STARBUCKS COFFEE 1251 GRAHAM ROAD FLORISSANT, MO 63031
	SHEET TITLE: LANDSCAPING PLAN SHEET NUMBER: L1.0



STARBUCKS COFFEE
COMPANY SOUTH
 2401 UTAH AVENUE SOUTH
 SEATTLE, WASHINGTON 98134
 (206) 318-1575

THESE DRAWINGS AND SPECIFICATIONS ARE PREPARED BY THE ARCHITECT AND THE CONTRACTOR SHALL BE RESPONSIBLE FOR OBTAINING ALL NECESSARY PERMITS AND APPROVALS FROM THE CITY OF SEATTLE AND THE STATE OF WASHINGTON. THE ARCHITECT AND CONTRACTOR SHALL BE RESPONSIBLE FOR OBTAINING ALL NECESSARY PERMITS AND APPROVALS FROM THE CITY OF SEATTLE AND THE STATE OF WASHINGTON. THE ARCHITECT AND CONTRACTOR SHALL BE RESPONSIBLE FOR OBTAINING ALL NECESSARY PERMITS AND APPROVALS FROM THE CITY OF SEATTLE AND THE STATE OF WASHINGTON.

ARCHITECT OF RECORD
 THIS DRAWING IS A DESIGN DEVELOPMENT DOCUMENT. THE ARCHITECT MAKES NO WARRANTY TO THE DESIGNER, CONTRACTOR, OR ANY OTHER PARTY REGARDING THE ACCURACY OF THE INFORMATION PROVIDED IN THIS DOCUMENT FOR RECORDING PURPOSES OR FOR CONSTRUCTION.

Rev	Date	Description
1	12/14/19	PLANT REVIEW SET

PROJECT NAME
GRAHAM & I-270
PROJECT ADDRESS
 1261 GRAHAM RD
 FLOISSANT, MO 63031

STORE # 13511
PROJECT # 98139-022
CONCEPT PALETTE
ISSUE DATE DECEMBER 14, 2019
DESIGN MANAGER TANNER WEST
LEEDS AP
PRODUCTION/ISSUED BY ZWA
CHECKED BY ZWA
SHEET TITLE

SCALE As indicated
SHEET NUMBER PL-0001

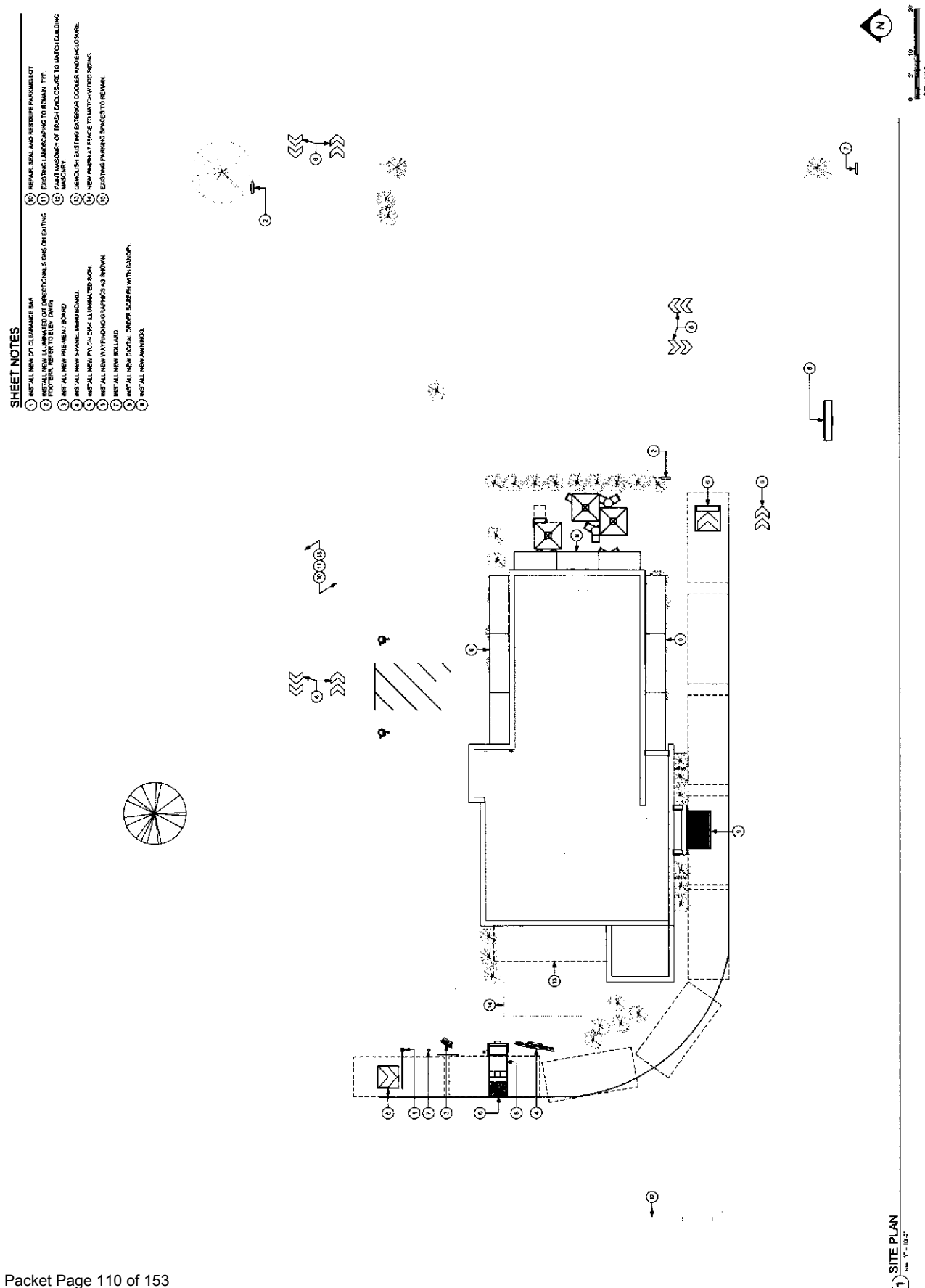

SHEET NOTES

- 1. INSTALL NEW 6" CLEARANCE SIGN
- 2. INSTALL NEW ILLUMINATED 6" DIRECTIONAL SIGN ON EXISTING POSTER SIGN TO LEFT OF SIGN
- 3. INSTALL NEW PREHEAT SIGN
- 4. INSTALL NEW PANEL ILLUMINATED SIGN
- 5. INSTALL NEW Pylon SIGN ILLUMINATED SIGN
- 6. INSTALL NEW WAYFINDING GRAPHICS AS SHOWN
- 7. INSTALL NEW BOLLARD
- 8. INSTALL NEW DIGITAL ORDER SCREEN WITH CANOPY
- 9. INSTALL NEW WININGS
- 10. REPAIR SEAL AND RESEALER PARKING LOT
- 11. EXISTING LANDSCAPING TO REMAIN. TYP.
- 12. PAINT MASONRY OF TRASH ENCLOSURE TO MATCH BUILDING MASONRY
- 13. DEMOLISH EXISTING EXTERIOR DOOR AND ENCLOSURE
- 14. NEW PREHAT FENCE TO MATCH WOOD SIGN
- 15. EXISTING PARKING SPACES TO REMAIN



STARBUCKS COFFEE
 COMPANY
 3000 15TH AVENUE
 SEATTLE WASHINGTON 98134
 (206) 318-1575

THESE DRAWINGS AND SPECIFICATIONS ARE
 PREPARED BY STARBUCKS COFFEE COMPANY
 ARCHITECTS AND SHALL REMAIN THE SOLE
 PROPERTY OF STARBUCKS COFFEE COMPANY.
 NO PART OF THESE DRAWINGS OR SPECIFICATIONS
 SHALL BE REPRODUCED OR TRANSMITTED IN ANY
 FORM OR BY ANY MEANS, ELECTRONIC OR
 MECHANICAL, INCLUDING PHOTOCOPYING,
 RECORDING, OR BY ANY INFORMATION STORAGE
 AND RETRIEVAL SYSTEM, WITHOUT THE WRITTEN
 PERMISSION OF STARBUCKS COFFEE COMPANY.
 ANY REPRODUCTION OR TRANSMISSION OF THESE
 DRAWINGS OR SPECIFICATIONS WITHOUT THE
 WRITTEN PERMISSION OF STARBUCKS COFFEE
 COMPANY IS STRICTLY PROHIBITED.

ARCHITECT OF RECORD
 HOK
 1000 15TH AVENUE
 SEATTLE WASHINGTON 98134
 (206) 461-1000

NO.	DATE	DESCRIPTION
1	10/11/17	PERMITS
2	10/11/17	PERMITS
3	10/11/17	PERMITS
4	10/11/17	PERMITS
5	10/11/17	PERMITS
6	10/11/17	PERMITS
7	10/11/17	PERMITS
8	10/11/17	PERMITS
9	10/11/17	PERMITS
10	10/11/17	PERMITS
11	10/11/17	PERMITS
12	10/11/17	PERMITS
13	10/11/17	PERMITS
14	10/11/17	PERMITS
15	10/11/17	PERMITS
16	10/11/17	PERMITS
17	10/11/17	PERMITS
18	10/11/17	PERMITS
19	10/11/17	PERMITS
20	10/11/17	PERMITS

PROJECT NAME:
GRAHAM & I-270
 PROJECT ADDRESS:
**1261 GRAHAM RD
 FLOISSANT, MO 63031**

STORE #: 1511
 PROJECT #: 3919-022
 CONCEPT:
 PALETTE:
 ISSUE DATE: DECEMBER 14, 2016
 DESIGN MANAGER: TANNER WEST
 LEED: LEED@CAP
 PRODUCTION DESIGNER: JWA
 CHECKED BY: JWA

SHEET TITLE:
**EXISTING EXTERIOR
 ELEVATIONS**
 SCALE:
 1/8" = 1'-0"

SHEET NUMBER:
PL-0002

SHEET NOTES

- 1 EXISTING LODG (SEE AREA 1-76)
- 2 EXISTING STANDING WOODWORK (AREA 1-21750)
- 3 EXISTING DRIVE THRU SERVICE (AREA 1-36)
- 4 EXISTING GREEN CANVAS AWNING, TYP.
- 5 EXISTING GREEN CANVAS DRIVE THRU AWNING
- 6 EXISTING SECURITY LIGHTS, TYP.
- 7 EXISTING BTM
- 8 EXISTING STORAGE HOOKS
- 9 EXISTING CAPE WINDOWS
- 10 EXISTING METAL PARAPET CORING
- 11 EXISTING WOOD SIDING
- 12 EXISTING BRICK, PAINTED
- 13 EXISTING DOOR
- 14 EXISTING LANDSCAPING TO REMAIN, TYP.
- 15 EXISTING COOL BI ENCLOSURE

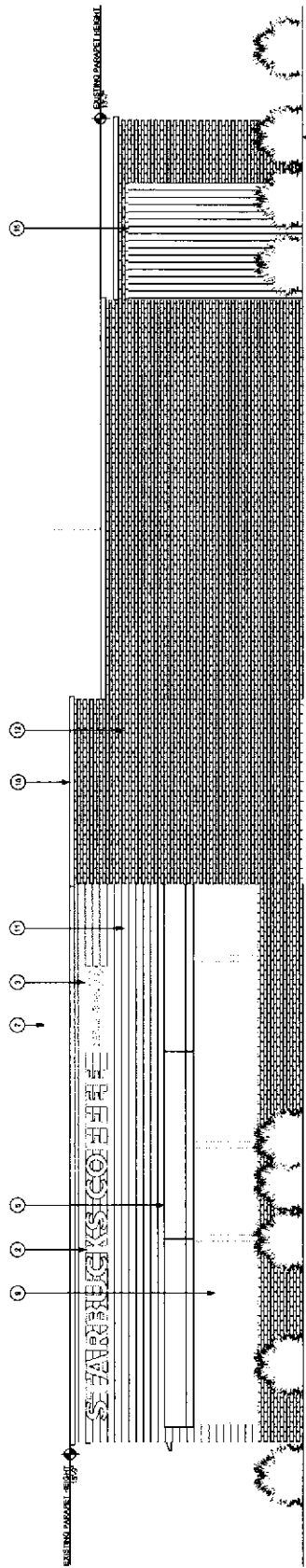

3 NORTH ELEVATION - EXISTING
 1/8" = 1'-0"

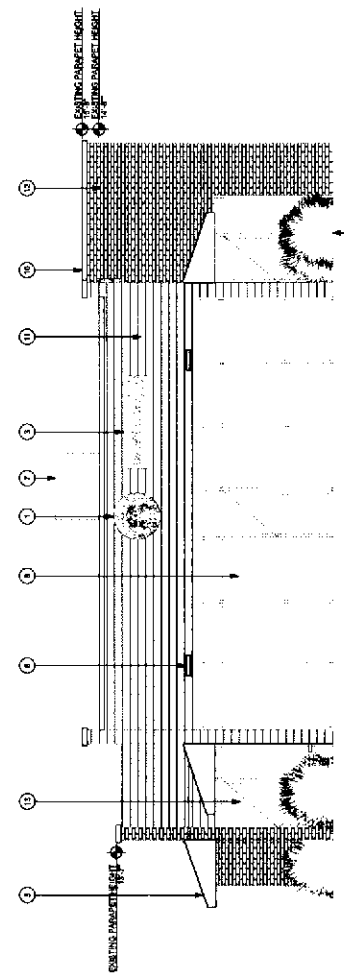

2 EAST ELEVATION - EXISTING
 1/8" = 1'-0"



STARBUCKS COFFEE
COMPANY SOUTH
 3401 UNIVERSITY AVENUE
 SEATTLE, WASHINGTON 98114
 (206) 318-1575

THESE DRAWINGS AND SPECIFICATIONS ARE PREPARED BY THE ARCHITECT FOR THE PROJECT AND THE OWNER OF THE PROJECT. THE ARCHITECT AND OWNER MAKE NO WARRANTY, EXPRESS OR IMPLIED, AS TO THE ACCURACY, COMPLETENESS, OR SUITABILITY OF THE INFORMATION CONTAINED HEREIN. THE ARCHITECT AND OWNER SHALL NOT BE RESPONSIBLE FOR ANY ERRORS, OMISSIONS, OR INADEQUACIES IN THE INFORMATION CONTAINED HEREIN. THE ARCHITECT AND OWNER SHALL NOT BE RESPONSIBLE FOR ANY DAMAGES, INCLUDING REASONABLE ATTORNEY'S FEES, ARISING OUT OF OR RESULTING FROM THE USE OF THE INFORMATION CONTAINED HEREIN. THE ARCHITECT AND OWNER SHALL NOT BE RESPONSIBLE FOR ANY DAMAGES, INCLUDING REASONABLE ATTORNEY'S FEES, ARISING OUT OF OR RESULTING FROM THE USE OF THE INFORMATION CONTAINED HEREIN.

ARCHITECT OF RECORD
 THIS DRAWING IS A DESIGN DEVELOPMENT DOCUMENT. THE ARCHITECT MAKES NO WARRANTY, EXPRESS OR IMPLIED, AS TO THE ACCURACY, COMPLETENESS, OR SUITABILITY OF THE INFORMATION CONTAINED HEREIN. THE ARCHITECT AND OWNER SHALL NOT BE RESPONSIBLE FOR ANY DAMAGES, INCLUDING REASONABLE ATTORNEY'S FEES, ARISING OUT OF OR RESULTING FROM THE USE OF THE INFORMATION CONTAINED HEREIN.

Date	By	Description
12/14/2016	PL	PLANT REVIEW

PROJECT NAME
GRAHAM & I-270
 1261 GRAHAM RD
 FLOISSANT, MO 63031

STORE # 13511
 PROJECT # 38136-022
 CONCEPT
 PALETTE
 ISSUE DATE: DECEMBER 14, 2016
 DESIGN MANAGER: TAMAR MEHTA
 LEED: LEED@AP
 PRODUCTION DESIGNED: DWA
 CHECKED BY: ZWA

SHEET TITLE
EXISTING EXTERIOR ELEVATIONS
 SCALE: 1/4" = 1'-0"
 SHEET NUMBER: PL-0003

SHEET NOTES

- 1 EXISTING LOGO SIGN (AREA - 14) SEE P.002
- 2 EXISTING STARBUCKS SIGN (AREA - 21) SEE P.002
- 3 EXISTING DRIVE THRU SIGNAGE (AREA - 58) SEE P.002
- 4 EXISTING GREEN CANVAS SIGNAGE TYP
- 5 EXISTING GREEN CANVAS DRIVE THRU SIGNAGE
- 6 EXISTING SECURITY LIGHTS TYP
- 7 EXISTING SIGN
- 8 EXISTING DIFFERENT WINDOWS SEE P.002
- 9 EXISTING JOE TIMMONS
- 10 EXISTING METAL FRAME/T FORMING
- 11 EXISTING WOOD SIGNING
- 12 EXISTING BRICK PAINTED
- 13 EXISTING DOOR SEE P.002
- 14 EXISTING LANDSCAPING TO REMAIN TYP
- 15 EXISTING COOLER ENCLOSURE

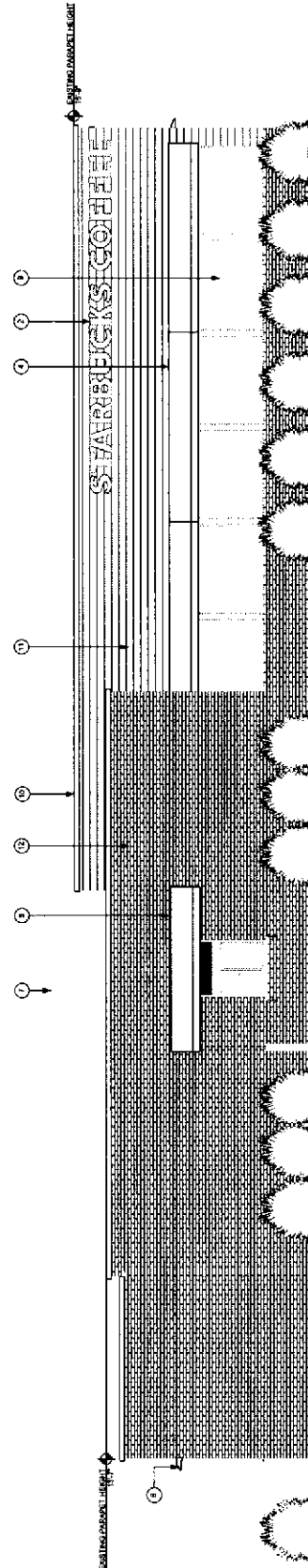

3 SOUTH ELEVATION - EXISTING
 Scale: 1/4" = 1'-0"

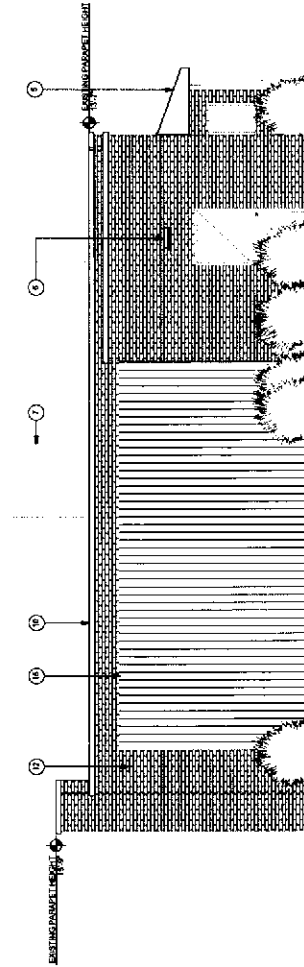

2 WEST ELEVATION - EXISTING
 Scale: 1/4" = 1'-0"



STARBUCKS COFFEE
COMPANY
3901 UNIVERSITY
SEATTLE, WASHINGTON 98144
(206) 318-1675

THESE DIMENSIONS AND SPECIFICATIONS ARE
FOR INFORMATION ONLY AND SHALL REMAIN THE SOLE
PROPERTY OF STARBUCKS COFFEE COMPANY. ANY
ATTEMPT TO REPRODUCE OR TRANSMIT THIS DOCUMENT IN
ANY MANNER OR IN ANY MEDIUM, WITHOUT THE WRITTEN
CONSENT OF STARBUCKS COFFEE COMPANY, IS STRICTLY
PROHIBITED. STARBUCKS COFFEE COMPANY SHALL NOT BE
RESPONSIBLE FOR ANY ERRORS OR OMISSIONS IN THIS
DOCUMENT. THE ARCHITECT'S OBLIGATION IS LIMITED TO
THE DESIGN OF THE BUILDING AND THE MATERIALS AND
METHODS SPECIFIED HEREIN. THE ARCHITECT SHALL NOT
BE RESPONSIBLE FOR THE ACCURACY OF ANY INFORMATION
CONTAINED IN THIS DOCUMENT THAT IS NOT THE PROPERTY
OF STARBUCKS COFFEE COMPANY.

ARCHITECT OF RECORD
GRAHAM & 1-270
1261 GRAHAM RD
FLORISSANT, MO 63031

Date	Description
12/11/19	PLAN REVIEW 04

PROJECT NAME
GRAHAM & 1-270
PROJECT ADDRESS
1261 GRAHAM RD
FLORISSANT, MO 63031

STORE # 13511
PROJECT # 38138-022
CONCEPT PALETTE
ISSUE DATE OCTOBER 14, 2019
DESIGN MANAGER TANNER WEST
LEADS @ GUP
PRODUCTION DESIGNER NWA
CHECKED BY NWA
SHEET TITLE
PROPOSED EXTERIOR ELEVATIONS
SCALE 1/4" = 1'-0"

PROJECT NUMBER
PL-0004

SHEET NOTES

- 1) INSTALL NEW LOGO SIGN (AREA = 18 SQ.) SEE PLAN 05
- 2) INSTALL NEW STAIRCASE WORKMARK (AREA = 20 SQ.)
- 3) INSTALL NEW DRIVING THROUGH SIGNAGE (AREA = 30 SQ.)
- 4) INSTALL NEW BLACK CANOPY (MINIMUM 11' x 11')
- 5) INSTALL NEW DRIVE THROUGH CANOPY
- 6) INSTALL NEW SIGNAGES, TYP.
- 7) RAISE PARAPET TO UNIFY OVERALL PROFILE AND RISE WITH ADJ. BUILDING PROFILE
- 8) ADAPT DRIVE THRU RAMP PARAPET TO BE CONSISTENT WITH BUILDING PROFILE
- 9) INSTALL NEW SLOPESIDE WINDOW TO MATCH EXISTING STOREFRONT WINDOWS
- 10) INSTALL NEW BLACK METAL PARAPET CORNER
- 11) INSTALL NEW WOOD-SHEDDING (MICHINA - VANTAGEWOOD - BARR)
- 12) PAINT EXISTING BRICK (BW733) - MEGA GRABBER
- 13) NEW BRICK WALL AND BRICK VENEER PAINTED TO MATCH EXISTING BRICK
- 14) EXISTING LANDSCAPING TO REMAIN, TYP.

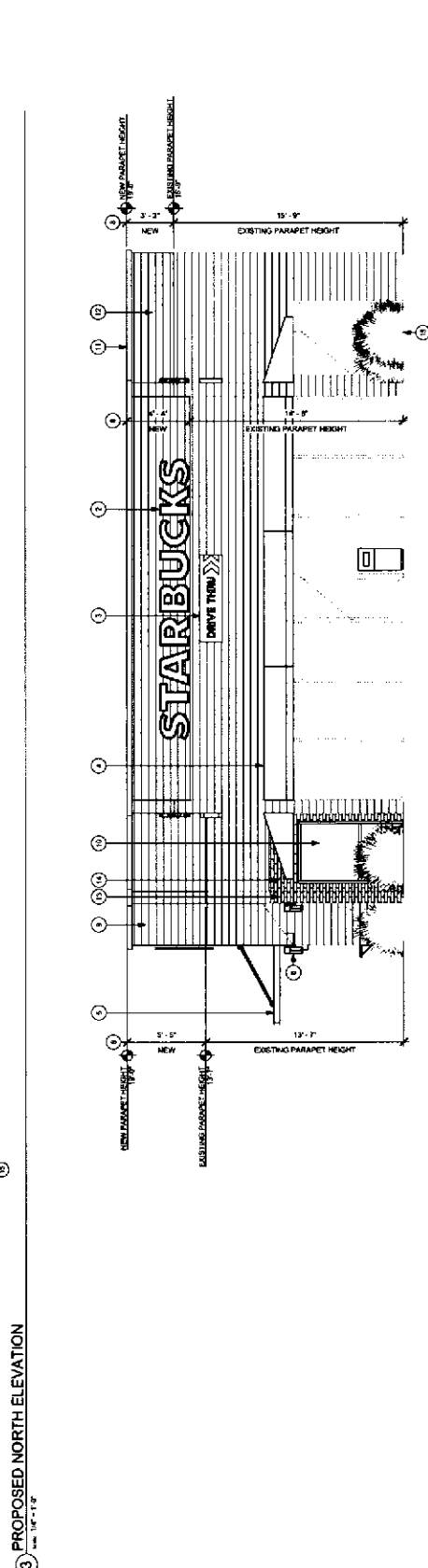
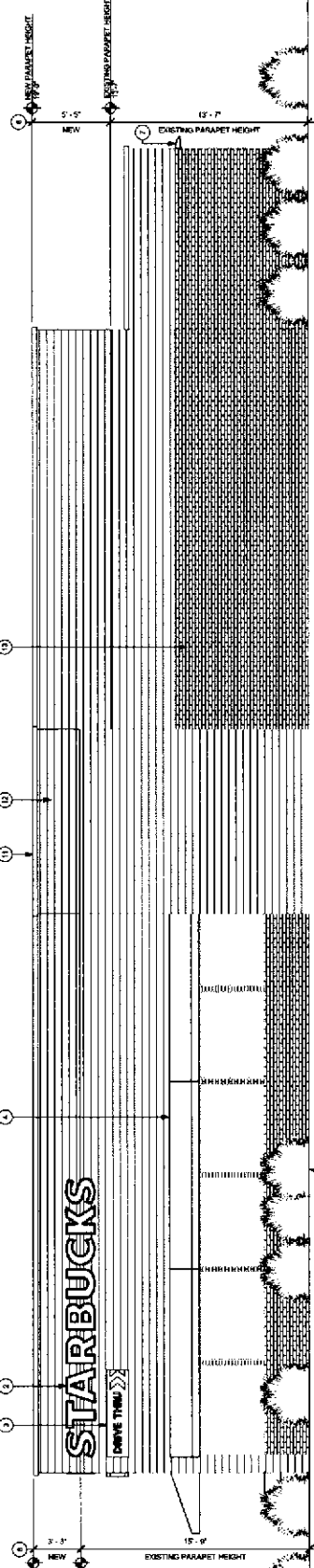



STARBUCKS COFFEE COMPANY
 SOUTH
 SEATTLE, WASHINGTON 98134
 (206) 318-1575

THESE DRAWINGS AND SPECIFICATIONS ARE PREPARED BY THE ARCHITECT AND SHALL BE CONSIDERED COMPLETE AND FINAL. THE CONTRACTOR SHALL BE RESPONSIBLE FOR OBTAINING ALL NECESSARY PERMITS AND FOR VERIFYING THE EXISTING CONDITIONS AND CONDITIONS OF THE SITE. THE CONTRACTOR SHALL BE RESPONSIBLE FOR OBTAINING ALL NECESSARY PERMITS AND FOR VERIFYING THE EXISTING CONDITIONS AND CONDITIONS OF THE SITE. THE CONTRACTOR SHALL BE RESPONSIBLE FOR OBTAINING ALL NECESSARY PERMITS AND FOR VERIFYING THE EXISTING CONDITIONS AND CONDITIONS OF THE SITE.

ARCHITECT OF RECORD
 THE DRAWING IS A PERSONAL REPRESENTATION OF THE ARCHITECT'S DESIGN AND SHALL NOT BE USED FOR ANY OTHER PROJECT WITHOUT THE WRITTEN CONSENT OF THE ARCHITECT. THE ARCHITECT SHALL BE RESPONSIBLE FOR OBTAINING ALL NECESSARY PERMITS AND FOR VERIFYING THE EXISTING CONDITIONS AND CONDITIONS OF THE SITE. THE CONTRACTOR SHALL BE RESPONSIBLE FOR OBTAINING ALL NECESSARY PERMITS AND FOR VERIFYING THE EXISTING CONDITIONS AND CONDITIONS OF THE SITE.

Date	By	Description
12/15/11	PL	PERMITS/REVISED SET

Revision Schedule

PROJECT NAME
GRAHAM & 1-270

PROJECT ADDRESS
**1281 GRAHAM RD
 FLORISSANT, MD 63031**

STORE #
 13511

PROJECT #
 39136-022

CONCEPT
 PALETTE

ISSUE DATE
 DECEMBER 14, 2016

DESIGN NUMBER
 TAMMERTWEST

LEG/09/PP
 PRODUCTION REGION/CM, JVA, ZVA

CHECKED BY
 SHEET TITLE
PROPOSED EXTERIOR ELEVATIONS

SCALE
 SHEET NUMBER
PL-0005

SHEET NOTES

1. INSTALL NEW LUDO DRINK AREA - 19'x10' SEE FLOOR PLAN
2. INSTALL NEW STARBUCKS WORKAREA AREA 3'x6'
3. INSTALL NEW DRINKING STORAGE AREA 3'x4'
4. INSTALL NEW BLACK CANVAS AWNINGS, TYP
5. INSTALL NEW DRINKING CONCEPT
6. INSTALL NEW SIGNAGES, TYP
7. INSTALL NEW SECURITY LIGHTS, TYP
8. PAISE PARAPET TO UNIFY OVERALL PROFILE AND HIDE RAIN, WITH BUILDING PROFILE.
9. MERRY DRIVE THROUGH RAMP RAISE PARAPET TO BE CONSISTENT WITH BUILDING PROFILE.
10. PAINT EXISTING BRICK (SPT101) - MEDIUM CRUISE.
11. PAINT EXISTING BRICK (SPT101) - MEDIUM CRUISE.
12. NEW HAZEL WALL AND BRICK VENEER PAINTED TO MATCH EXISTING BRICK.
13. EXISTING LANDSCAPING TO REMAIN, TYP.
14. NEW PARAPET HEIGHT
15. EXISTING PARAPET HEIGHT
16. NEW PARAPET HEIGHT
17. EXISTING PARAPET HEIGHT
18. NEW PARAPET HEIGHT
19. EXISTING PARAPET HEIGHT
20. NEW PARAPET HEIGHT
21. EXISTING PARAPET HEIGHT
22. NEW PARAPET HEIGHT
23. EXISTING PARAPET HEIGHT
24. NEW PARAPET HEIGHT
25. EXISTING PARAPET HEIGHT
26. NEW PARAPET HEIGHT
27. EXISTING PARAPET HEIGHT
28. NEW PARAPET HEIGHT
29. EXISTING PARAPET HEIGHT
30. NEW PARAPET HEIGHT
31. EXISTING PARAPET HEIGHT
32. NEW PARAPET HEIGHT
33. EXISTING PARAPET HEIGHT
34. NEW PARAPET HEIGHT
35. EXISTING PARAPET HEIGHT
36. NEW PARAPET HEIGHT
37. EXISTING PARAPET HEIGHT
38. NEW PARAPET HEIGHT
39. EXISTING PARAPET HEIGHT
40. NEW PARAPET HEIGHT
41. EXISTING PARAPET HEIGHT
42. NEW PARAPET HEIGHT
43. EXISTING PARAPET HEIGHT
44. NEW PARAPET HEIGHT
45. EXISTING PARAPET HEIGHT
46. NEW PARAPET HEIGHT
47. EXISTING PARAPET HEIGHT
48. NEW PARAPET HEIGHT
49. EXISTING PARAPET HEIGHT
50. NEW PARAPET HEIGHT
51. EXISTING PARAPET HEIGHT
52. NEW PARAPET HEIGHT
53. EXISTING PARAPET HEIGHT
54. NEW PARAPET HEIGHT
55. EXISTING PARAPET HEIGHT
56. NEW PARAPET HEIGHT
57. EXISTING PARAPET HEIGHT
58. NEW PARAPET HEIGHT
59. EXISTING PARAPET HEIGHT
60. NEW PARAPET HEIGHT

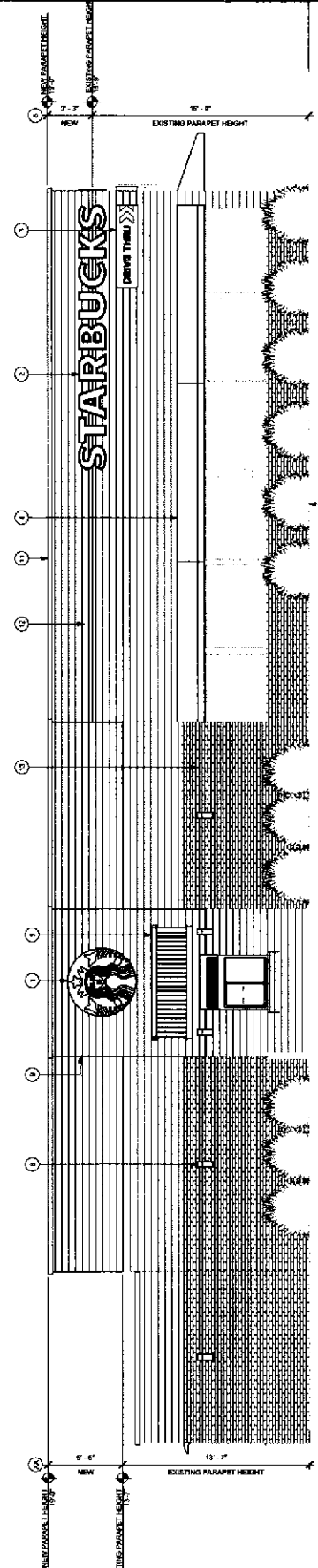

3. PROPOSED SOUTH ELEVATION
 Scale: 1/8" = 1'-0"

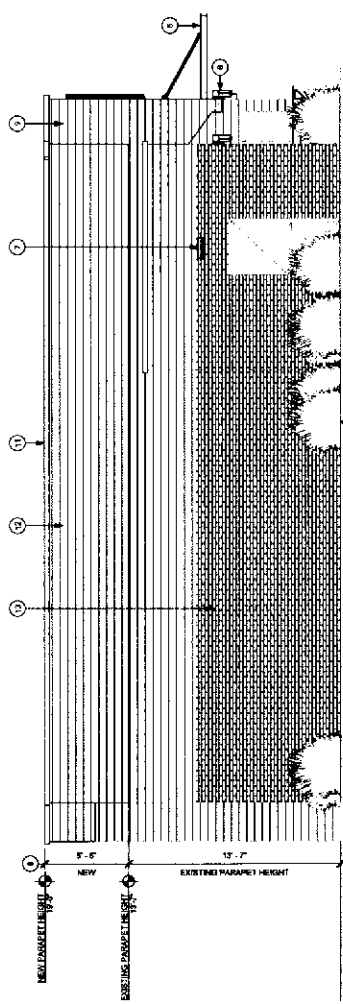

2. PROPOSED WEST ELEVATION
 Scale: 1/8" = 1'-0"

1

MEMORANDUM

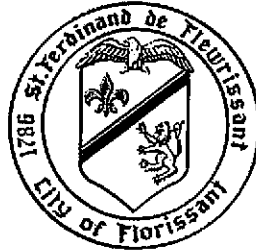

2

CITY OF FLORISSANT

3

"Preserve and improve the health, safety, and welfare of our residents, businesses and the general public in the City of Florissant; while at the same time maintaining property values and improving the quality of life in the City of Florissant."

4

5

6

To: Planning and Zoning Commissioners Date: December 21, 2016

7

8

From: Philip E. Lum, AIA-Building Commissioner cc: Louis B. Jearls, Jr. PE-PWLF
Director of Public Works
Applicant
File

9

10

11

12

13

Subject: 1261 Graham Road (Starbucks) - Request recommended approval to amend a Special Use, ordinance no. 7398, in a 'B-3' Zoning District.

14

15

16

STAFF REPORT

17

CASE NUMBER PZ-100317-4

18

19

I. PROJECT DESCRIPTION:

This is a request for recommended approval to amend a Special Use, ordinance no. 7398, in a 'B-3' Zoning District to allow a remodeling of the exterior.

20

21

22

23

II. EXISTING SITE CONDITIONS:

The existing property at 1261 Graham Road is a 3024 s.f. according to public record. It has been in operation since 2007 and would like to apply for permit for exterior alterations.

24

25

26

27

28

III. SURROUNDING PROPERTIES:

The adjacent property to the North is 1225 Graham Road in a 'B-5' District. The property to the west is 1265 Graham in an 'B-3' District. The adjacent properties to the South are 1275 Graham and 55 Dunn Road also in the 'B-3' District.

29

30

31

32

33

IV. STAFF ANALYSIS:

The application is accompanied by professional plans PL-001 Site Plan, PL-002 Existing Exterior Elevations, PL-003 Existing Exterior Elevations, PL-004 Proposed Exterior Elevations, PL-005 Proposed Exterior Elevations, all dated December 14, 2016. Staff has the following review comments:

34

35

36

37

38

39

40 General: The Existing building consists of painted masonry. Upon examination of
41 elevations, there is brick that is being covered by siding. Petitioner should come prepared
42 to discuss how much painted masonry is being covered.
43

44 PL-001 Site Plan: shows the following changes:

- 45 a. Shows improvements to the drive-through.
- 46 b. Indicates new awnings and screen.
- 47 c. Removal of existing cooler.
- 48 d. Re-seal and restriping of existing parking lot.

49 PL-004 and PL-005 Proposed Exterior Elevations

- 50 a. Shows new Nichiha Siding, a composite material
 - 51 b. Indicates new canvas awnings.
 - 52 c. All signs shown are within sizes permitted under the City Sign Code.
- 53

54 V. MASONRY ORD. ANALYSIS

55 This proposal freshens the exterior with a new look and painted areas remain painted.
56 Brick is to remain painted, but some is covered up. Painting to new color shall be
57 recommended to Council.
58

59 VI. STAFF RECOMMENDATIONS:

- 60 1. The exterior changes affect the existing Special Use.
 - 61 2. Any other items in need of change to the ordinance may be considered.
- 62

63 **Suggested Motion to Amend a Special Use:**

- 64
- 65 1. I move to recommended approval to amend a Special Use, ordinance no. 7398, in
66 a 'B-3' Zoning District to allow a remodeling of the exterior, according to the
67 proposal prepared by the petitioner as described related documents presented **and**
68 **according to the attached drawings as prepared by Starbucks Coffee**
69 **Company and dated 12/14/16.** Approval is subject to the regulations of these
70 ordinances, and the following additional requirements:
71

72 1. **GENERAL DEVELOPMENT CONDITIONS.**

- 73
- 74 a. Unless, and except to the extent, otherwise specifically provided in
75 ordinance no. 7398, development shall be effected only in accordance with
76 all ordinances of the City of Florissant.
77

78 2. **PROJECT COMPLETION.**

79 Construction shall start within 90 days of the issuance of building permits for
80 the project and shall be developed in accordance of the approved final
81 development plan within 180 days of start of construction.
82

83 (End of report and suggested motion 12/21/16)



CITY OF FLORISSANT – Health Department

Application for Keeping domestic animals, fowl or bees

Applicant Name: Donna J. Scholl Address: 1485 Lindsay Ln.

Home Phone: 314-921-4845 Cell Phone: 314-757-4206

Designate number & type of animal(s) to be kept: 3 hens

Designate where animal(s), fowl or bees will be kept: coop + run in backyard

Facilities/shelter to be provided: Fenced in coop
Fresh covering over coop + fencing

Size of applicant's property: 132' x 94'

Are the animals being requested on the application going to be bred or used for a home business in any way? NO

What other animals are being kept on the premises? 1 dog - Registered and good city tag

Has the applicant spoken with adjoining property owners concerning this application? [X] YES [] NO

The following documentation is required and has been attached to this application:

- [X] Plot plan/drawings showing property and location of animal housing, pen or cage.
[] Veterinarian statement of Health risks and vaccination requirements.

I HAVE READ & DO HEREBY UNDERSTAND THE ORDINANCES PRINTED ON THE REVERSE SIDE OF THIS FORM PERTAINING TO THIS APPLICATION AND PERMIT.

Applicant Signature: Donna J. Scholl Date: 1-24-17

Health Department Action & Recommendation: Approve

Health Superintendent: Fred Schatz Date: 1-24-17

Director of Public Works: Lou Jankis Date: 1-24-17

94.94

132.03

Lindsay Lane

sidewalk

157.34

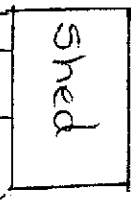
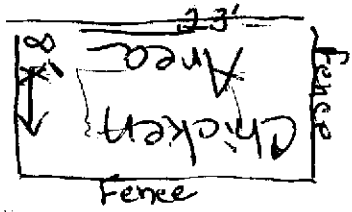
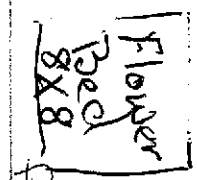

Tree

Patio

Garage

Drive way

sidewalk



House



sidewalk

fence

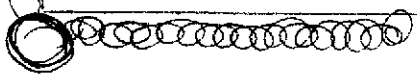

side walk

70.30

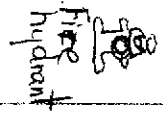

Thomas J. Brown

TITLE INSURANCE • CERTIFICATES OF TITLE • ESCROWS

94-94

30.41

197.34

FRANCISCA ADDITION

PART OF SURVEYS 74, 175 & 176
ST. FERDINAND COMMONFIELDS

RAINWOOD ??

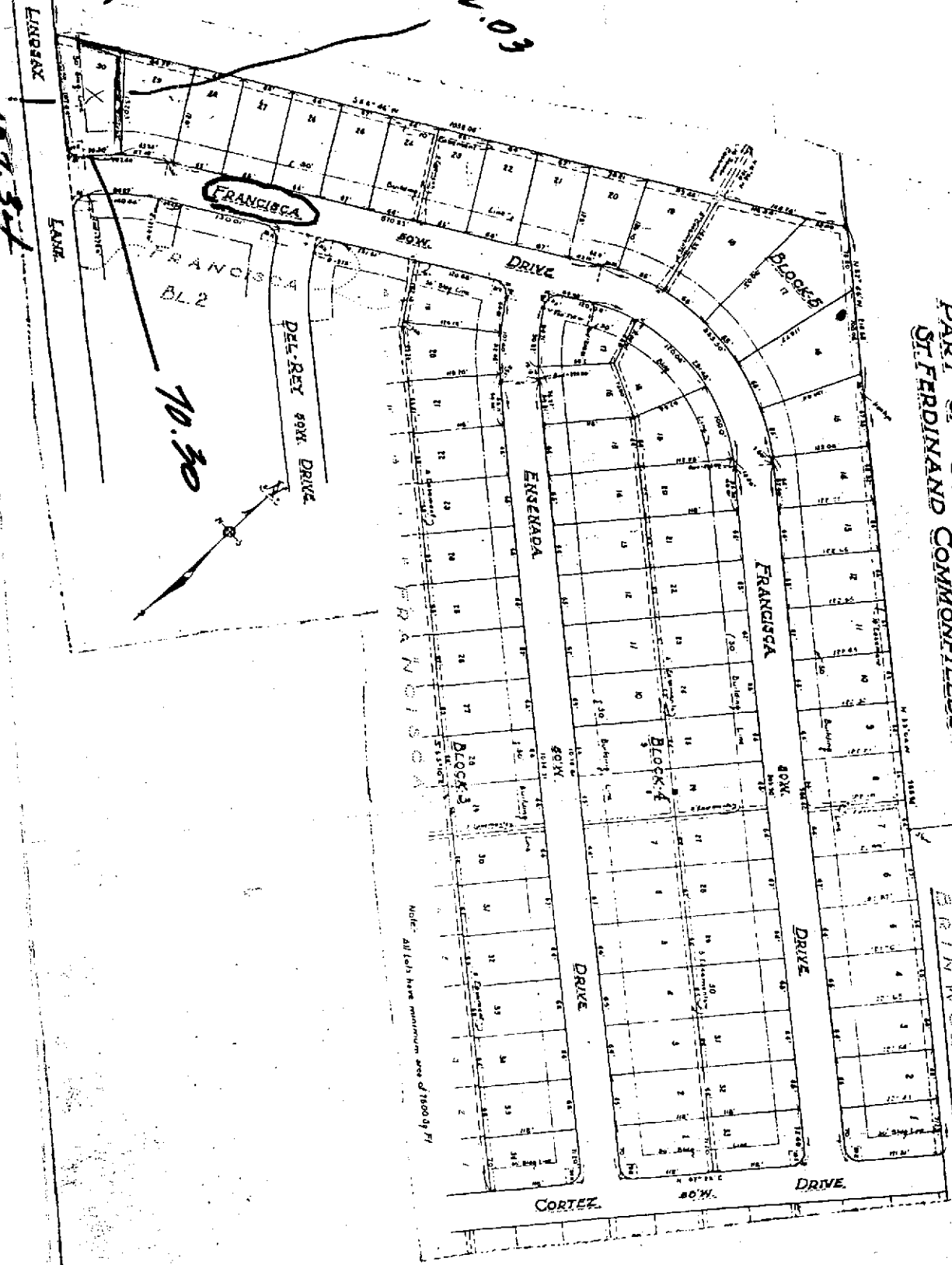



CITY OF FLORISSANT HEALTH DEPARTMENT
Animal Permit Application – Neighbor Approval Form

Florissant City Code 205.360 requires any property owner proposing to keep domestic animals, fowl or bees other than the usual children's pets to obtain a permit. As part of this process, applicants must advise immediate neighbors of their intentions and receive approval from any adjoining property owners. If neighbor is a renter then approval must be obtained from both the renter AND property owner.

APPLICANT NAME: Donna J. Schell
 SITE ADDRESS: 1485 Lindsay Lane
 TYPE OF ANIMAL BEING APPLIED FOR: hens

I/we, being the abutting property owner(s), have no objections to the above named property owner keeping the animal(s) described above in accordance with Florissant City Code.

Abutting Property Owner Name & Signature	Address	Phone	Date
Cathryn Graham <i>Cathryn Graham</i> David Graham <i>David Graham</i>	15 Francisca Dr Florissant, MO 63031	314-921-0119	1/19/17
<i>Josser Good</i>	900 Shackelford Florissant, MO	314-325-5550	1/22/17

Anyone with questions or concerns may call the Florissant Health Department at 314-839-7655 Monday - Friday

Donna J. Scholl

TSC TRACTOR SUPPLY CO.

Bring the country feel to the city with the Precision Pet Farm House Coop! This complete home for chickens includes 3 roosting bars, a sliding door to secure chickens at night, an easy to pull out pan for cleaning, and 3 nesting boxes. Each coop is weather resistant with an asphalt shingled roof and weather resistant coating.

- Included instructions allow for easy assembly with just a screw driver
- Add a backyard with the attachable Farm Expansive House Pen that is also available for purchase
- Houses up to 6 chickens
- Size: 73 in. x 38.25 in. x 46 in.



\$189.99

Was \$229.99

Save \$40.00

Online Only Price

SKU #115225399



BUY ONLINE PICK UP IN STORE

Pen Included:

Product Height:

Product Length:

Product Type:

Product Weight:

Product Width:

Recommended Number of Chickens:

Roof Material:

Wall Material:

Warranty:

Manufacturer Part Number

Description

Precision Pet Products

No

46 in.

73 in.

6 - 8 Bird Coops

90 lb.

38-1/2 in.

6-8 Chickens

Asphalt

Fir Wood

1-Year Limited

29127

Permit Application for Chickens
City of Florissant
CHECK-LIST

- Completed application ... (attached)
 - Hens only, no roosters
 - Maximum 4 hens allowed
 - Non-commercial use only (no breeding or selling of eggs, for personal use only)
 - Will chickens be kept on 3 acres or more?
 - What is the current zoning of property?
 - Applicant agrees to yearly inspection by the City, as warranted
- Has applicant contacted the neighbors?
(May not be required on 3 acres or more)
- ~~Has veterinarian statement concerning health risks and vaccination been addressed~~
- Plot plan with dimensions showing location of proposed chicken coop ...
(Chicken coops will be treated as accessory structures, and must meet all City building and zoning codes.)
- Detailed drawing showing dimensions of chicken coop and construction materials
 - Predator- proof
 - Secure from rodents (rats)
 - Adequate ventilation, adjustable for summer and winter conditions
 - Appropriate lighting
 - Easy to clean
 - Roosting poles for sleeping with removable "droppings tray" under each pole
 - Provide one nest box for every four hens
 - Provide at least 10 square feet per hen if they are permanently confined; 4 square feet per hen if they can roam freely during the day
 - Provide adequate feeder and water, 6-8 inches off the ground
 - Construction materials must be sturdy, able to withstand local weather conditions, painted/stained/sealed appropriately, of quality workmanship and meet local building standards & practices.
- Photo's if applicable
- Health Department recommendations and approval
- Director of Public Works and Health approval
- Approval of City Council

5.15.12

TRANSFER OF SPECIAL PERMIT

AUTHORIZED BY ORDINANCE NUMBER (S) 7716

FROM Tot Lots Learning Center

TO Florissant Kids Care Center LLC

FOR Day Care

ADDRESS 2184 N. Waterford Drive, Florissant, MO 63031

Ward 9 Zoning _____ Date Filed 2/7/2017 Accepted By [Signature]

TRANSFER OF SPECIAL USE PERMIT PETITION

TO THE CITY COUNCIL OF THE CITY OF FLORISSANT:

1. Comes now Elizabeth Johnson and states to the City Council that he (she) (they) has (have) the following legal interest in the property located at 2184 N. Waterford Dr., Florissant, MO 63031 in the City of Florissant, Missouri. Legal interest: Lease or Simple Title
(Attach signed copy of lease or deed)

2. The petitioner(s) further state that he (she) (they) has (have) not made any arrangement to pay any commission, gratuity, or consideration, directly or indirectly to any official, employee, or appointee of the City of Florissant, with respect to this petition.

3. The applicant will operate the business in the same manner and under the same conditions as set out in the original ordinance granting the special permit or any amendments thereto, except for any proposed change in sign face of an authorized sign.

PETITIONER SIGNATURE Elizabeth Johnson
Individual's Name

FOR: Florissant Kidscare Center LLC
Company, Corporation, Partnership

2/8/17
CP to Council
Ressel + Mayor

4. I (we) hereby certify that (indicate **one** only):

I (we) have a legal interest in the above described property.

I am (we are) the duly appointed agent (s) of the petitioner, and that all information given is true and a statement of fact.

SIGNATURE Elizabeth Johnson

ADDRESS 260 North Jefferson, 63031

Telephone No. (314) 309-6698 Email address Elizabeth.A.Johnson87@gmail.com

I (we) the petitioner(s) do hereby appoint _____ as my (our) duly authorized agent to represent me (us) in regard to this petition.

Elizabeth Johnson
PETITIONER SIGNATURE

Note: Petitioner or his/her authorized agent will be the only person(s) permitted to make the presentation to the City Council.

5. Acknowledgement and consent of owner to Transfer Special Permit Petition.

Don Cherry
SIGNATURE OF OWNER
Don Cherry

Information sheet to be attached to all requests for Transfer of Special Permit

Type of Operation: (Select One)

Individual

Partnership

Corporation

LLC

INDIVIDUAL:

Name & address Elizabeth Johnson / 260 North Jefferson, 63031

Telephone number & email address (314) 482-6640 / ElizabethJohnson87@gmail.com

Business name/address/phone Florissant KidsCare

Copy of fictitious name registration, if applicable _____

PARTNERSHIP:

Name & address of partner (s) _____

Telephone number(s) and email address (s) _____

Business name/ address /phone _____

Copy of fictitious name registration, if applicable _____

CORPORATION OR LLC:

Name & address of all corporate officers _____

Telephone numbers & email addresses _____

Business name/address/phone _____

Photocopy of Corporation/LLC Articles and Certificate _____

Date of incorporation/LLC _____

Copy of fictitious name registration, if applicable

Copy of latest Missouri Anti-Trust affidavit (annual registration of corporate officers)



CITY OF FLORISSANT

Honorable Thomas P. Schneider, Mayor

TRANSFER OF SPECIAL USE PERMIT

The undersigned hereby acknowledges receipt of a copy of Ordinance
Number 7716 which authorized a Special Permit:

TO: Hot - Lots Learning Center

FOR: operation of a child care center

and agree to the terms and conditions listed in said ordinance and to any
additional term and conditions that the City Council shall deem appropriate.

Elizabeth Johnson

PRINT - NAME OF APPLICANT

Elizabeth Johnson

SIGNATURE OF APPLICANT

CITY HALL
955 Rue St. Francois
Florissant, MO 63031
314 / 921-5700
Fax: 314 / 921-7111
TDD: 314 / 839-5142

POLICE DEPARTMENT
1700 North Highway 67
Florissant, MO 63033
314 / 831-7000
Fax: 314 / 830-6045

PARKS DEPARTMENT
#1 James J. Eagan Drive
Florissant, MO 63033
314 / 921-4466
Fax: 314 / 839-7672

HEALTH DEPARTMENT
#1 St. Ferdinand Drive
Florissant, MO 63031
314 / 839-7654
Fax: 314 / 839-7656

MUNICIPAL COURT
1055 Rue St. Francois
Florissant, MO 63031
314 / 921-3322
Fax: 314 / 839-7663

www.florissantmo.com

1 INTRODUCED BY COUNCILMAN HERNANDEZ
2 JULY 12, 2010

3
4 BILL NO. 8635

ORDINANCE NO. 7716

5
6 **AN ORDINANCE GRANTING A SPECIAL USE PERMIT TO**
7 **ANTIONETTE FIELDS D/B/A TOT-LOTS LEARNING CENTER, LLC TO**
8 **ALLOW FOR AN CHILD CARE CENTER FOR THE PROPERTY**
9 **LOCATED AT 2184 N. WATERFORD.**

10
11 WHEREAS, the Florissant Zoning Ordinance authorizes the City Council of the City of
12 Florissant, by Special Use Permit, after public hearing thereon, to permit the operation of child care
13 center; and

14 WHEREAS, an application has been filed by Antoinette Fields d/b/a Tot-Lots Learning
15 Center, LLC for the operation of a child care center located at 21840 N. Waterford.

16 WHEREAS, the Planning and Zoning Commission of the City of Florissant, at their meeting
17 of June 21, 2010, has recommended that the said Special Use Permit be granted; and

18 WHEREAS, due notice of a public hearing on said application to be held on the 12th day of
19 July, 2010 at 8:00 P.M. by the Council of the City of Florissant was duly published, held and
20 concluded; and

21 WHEREAS, the Council, following said public hearing, and after due and careful
22 consideration, has concluded that the granting of the Special Use Permit as hereinafter provided
23 would be in the best interest of the City of Florissant.

24 NOW, THEREFORE, BE IT ORDAINED BY THE COUNCIL OF THE CITY OF
25 FLORISSANT, ST. LOUIS COUNTY, MISSOURI, AS FOLLOWS:

26
27 Section 1: A Special Use Permit is hereby granted to Antoinette Fields d/b/a Tot-Lots
28 Learning Center, LLC for the operation of an child care center located at 2184 N. Waterford with the
29 following stipulations:

- 30 1. A 6 foot sight-proof vinyl fence shall be placed around the playground.
31 2. A solid vinyl fence, with the appropriate closures shall be placed around the
32 trash dumpster.

33 Section 2: When the named permittee discontinues the operation of said business, the Special
34 Use Permit herein granted shall no longer be in force and effect.

35 Section 3: This ordinance shall become in force and effect immediately upon its passage and
36 approval.

37

38
39
40
41
42
43
44
45
46
47
48
49
50
51
52
53
54
55
56

Adopted this 26 day of July, 2010.

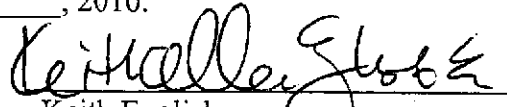
Keith English
President of the Council

Approved this 27 day of July, 2010.

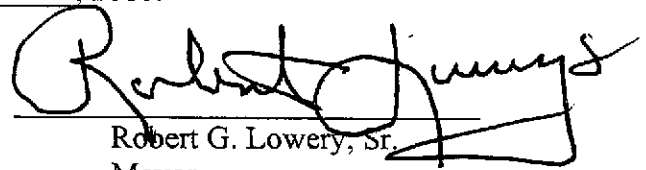
Robert G. Lowery, Sr.
Mayor

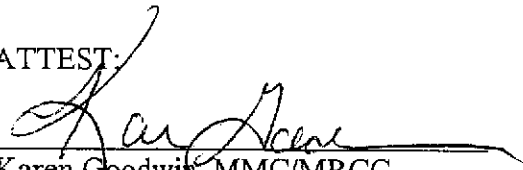
ATTEST:

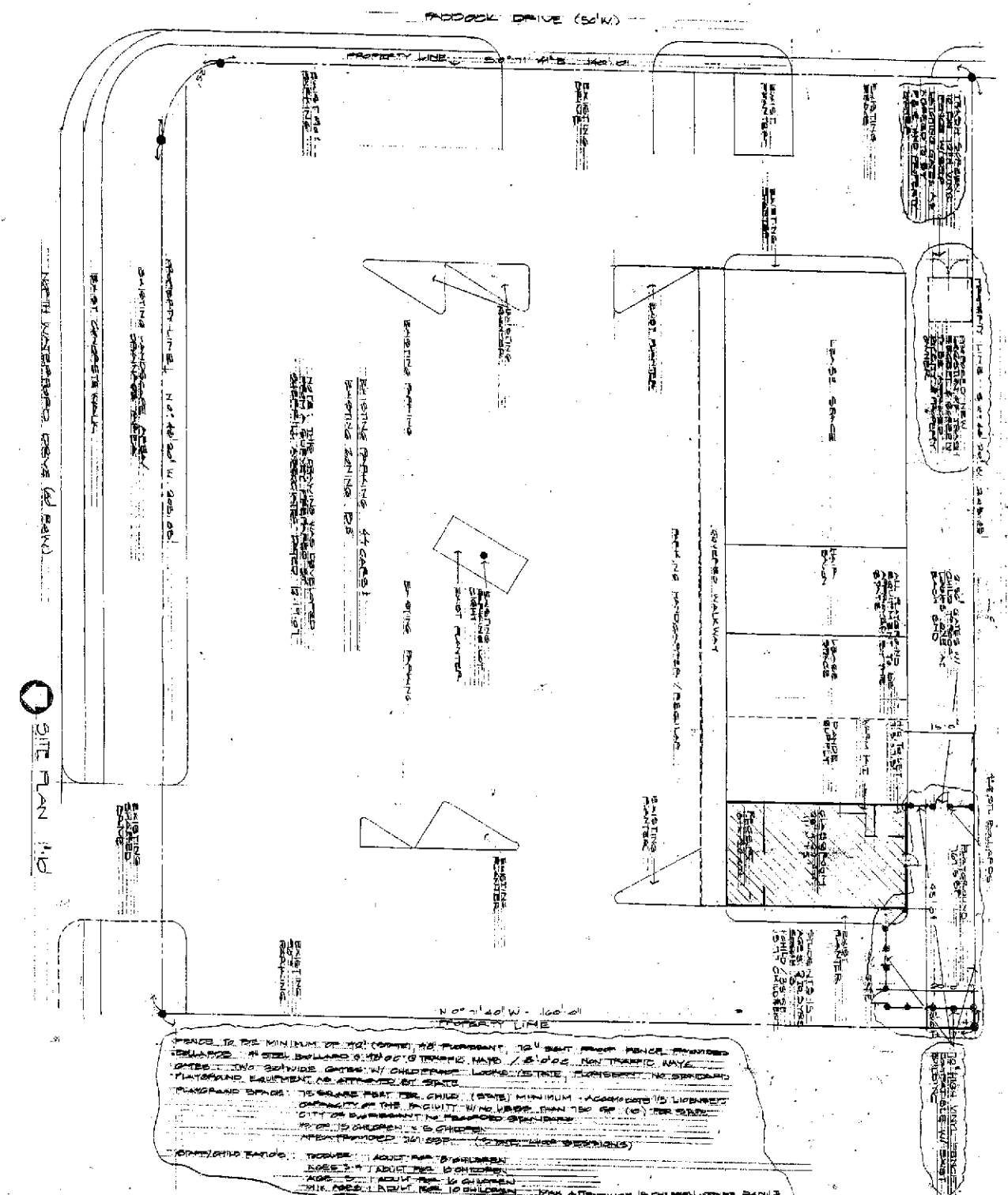
Karen Goodwin, MMC/MRCC
City Clerk



SITE PLAN 149

SPACES TO BE MINIMUM OF 20' (CONC) OR PLUMBENT 2" 1/2" BEAT (WOOD FENCE PROVIDED
 TO BE AT LEAST 6" ABOVE GROUND / 2" ABOVE TRAFFIC WAY / 2" ABOVE NON TRAFFIC WAY
 SUBJECT TO 30" WIDE GATES W/ CHILDREN LOCKS / NO TRAFFIC / NO TRAFFIC / NO TRAFFIC
 PLAYGROUND EQUIPMENT AS APPROVED BY STATE
 PLAYGROUND SPACES TO BE OPEN FOR ALL CHILD (STATE) MINIMUM - ACCOMMODATE 15 LICENSED
 CAPACITY OF THE FACILITY W/ NO MORE THAN 100 SF (10) PER CHILD
 CITY OF BURLINGTON PLANNING DEPARTMENT
 NO. OF CHILDREN TO BE SERVED
 AREA PROVIDED FOR USE (SEE DIST. LINE SPECIFICATIONS)
 CONSTRUCTION BANDS TO BE 12" ABOVE FOR CHILDREN
 12" ABOVE FOR ADULTS
 12" ABOVE FOR CHILDREN
 12" ABOVE FOR ADULTS
 12" ABOVE FOR CHILDREN
 12" ABOVE FOR ADULTS
 MAX ATTENDANCE 15 CHILDREN - 50 ADULTS

STUDIO
 1500 S. 11TH ST.
 SUITE 100
 OMAHA, NE 68106

TOTAL LOT
LEARNING CENTER
 2164 NORTH WATERFORD DRIVE
 FLORENCE, MISSOURI

GERRY HEINCKE ARCHITECT
 852 KINGSELEY DRIVE
 FLORENCE, MISSOURI 65058
 TEL: 314-782-2269
 FAX: 314-782-0786

STATE OF MISSOURI



Jason Kander
Secretary of State

CERTIFICATE OF ORGANIZATION

WHEREAS,

Florissant KidsCare Center LLC
LC001503417

filed its Articles of Organization with this office on the 16th day of August, 2016, and that filing was found to conform to the Missouri Limited Liability Company Act.

NOW, THEREFORE, I, Jason Kander, Secretary of State of the State of Missouri, do by virtue of the authority vested in me by law, do certify and declare that on the 16th day of August, 2016, the above entity is a Limited Liability Company, organized in this state and entitled to any rights granted to Limited Liability Companies.

IN TESTIMONY WHEREOF, I hereunto set my hand and cause to be affixed the GREAT SEAL of the State of Missouri.
Done at the City of Jefferson, this 16th day of August, 2016.

Secretary of State





State of Missouri
Jason Kander, Secretary of State
 Corporations Division
 PO Box 778 / 600 W. Main St., Rm. 322
 Jefferson City, MO 65102

LC001503417
Date Filed: 8/16/2016
Jason Kander
Missouri Secretary of State

Articles of Organization

(Submit with filing fee of \$105.00)

1. The name of the limited liability company is

Florissant KidsCare Center LLC

(Must include "Limited Liability Company," "Limited Company," "LC," "L.C.," "L.L.C.," or "LLC")

2. The purpose(s) for which the limited liability company is organized:

Childcare Services

3. The name and address of the limited liability company's registered agent in Missouri is:

elizabeth ashley

johnson

260 north jefferson

florissant MO 63031

Name

Street Address: May not use PO Box unless street address also provided

City/State/Zip

4. The management of the limited liability company is vested in: managers members *(check one)*

5. The events, if any, on which the limited liability company is to dissolve or the number of years the limited liability company is to continue, which may be any number or perpetual: Perpetual

(The answer to this question could cause possible tax consequences, you may wish to consult with your attorney or accountant!)

6. The name(s) and street address(es) of each organizer *(PO box may only be used in addition to a physical street address):*

(Organizer(s) are not required to be member(s), manager(s) or owner(s))

Name

Address

City/State/Zip

johnson, Elizabeth

260 north jjefferson

florissant MO 63031

7. Series LLC (OPTIONAL) Pursuant to Section 347.186, the limited liability company may establish a designated series in its operating agreement. The names of the series must include the full name of the limited liability company and are the following:

New Series:

The limited liability company gives notice that the series has limited liability.

New Series:

The limited liability company gives notice that the series has limited liability.

New Series:

The limited liability company gives notice that the series has limited liability.

(Each separate series must also file an Attachment Form LLC 1A.)

Name and address to return filed document:	
Name:	<u>elizabeth ashley johnson</u>
Address:	<u>Email: elizabethajohnson87@gmail.com</u>
City, State, and Zip Code:	_____

8. The effective date of this document is the date it is filed by the Secretary of State of Missouri unless a future date is otherwise indicated: _____

(Date may not be more than 90 days after the filing date in this office)

In Affirmation thereof, the facts stated above are true and correct:

(The undersigned understands that false statements made in this filing are subject to the penalties provided under Section 575.040, RSMo)

All organizers must sign:

Elizabeth Johnson
Organizer Signature

ELIZABETH JOHNSON
Printed Name

08/16/2016
Date of Signature

INTRODUCED BY COUNCIL AS A WHOLE
FEBRUARY 13, 2017

Resolution No. 993

A RESOLUTION AUTHORIZING THE MAYOR OF THE CITY OF FLORISSANT TO MAKE APPLICATION UNDER THE MUNICIPAL PARKS GRANT FOR PLANNING SERVICES AT MANION PARK FOR AN INCLUSIVE PLAYGROUND.

WHEREAS, the City of Florissant is an expanding City in the growing county of St. Louis; and

WHEREAS, the existing city has a population in excess of 52,000 people, and

WHEREAS, the City Council deems it necessary to construct an inclusive playground in Manion Park

NOW THEREFORE, BE IT RESOLVED BY THE COUNCIL OF THE CITY OF FLORISSANT as follows:

RESOLVED, that grant-in-aid applications be made under the Municipal Parks Grant of St. Louis County for 80% of costs for planning services at Manion Park, reimbursable upon completion by the Municipal Parks Grant Commission.

FURTHER RESOLVED, that a project proposal be submitted to the Municipal Parks Grant Commission and that the City Council authorizes the Mayor to sign and execute the necessary documents of said project proposal.

FURTHER RESOLVED, that if a grant is awarded, the City of Florissant will enter into an agreement or contract with the Municipal Parks Grant Commission regarding said grant.

PASSED AND RESOLVED THIS DAY OF February, 2017.

Jackie Pagano
President of the Council
City of Florissant

ATTEST:

Karen Goodwin, MMC/MRCC
CITY CLERK

Karen Goodwin

From: Todd Schmidt
Sent: Wednesday, February 08, 2017 7:04 PM
To: Karen Goodwin
Cc: Mayor Schneider; Cheryl Thompson
Subject: "Resolution" for Park Planning Services

Karen,

As you know, the Parks and Recreation Department has a proposed Resolution on the agenda for the City Council to review (and hopefully pass) at the next Council Meeting scheduled on Monday, February 13, 2017. The Resolution is pretty simple and straightforward. Also, the Council did pass a similar Resolution on November 9, 2015 for a Planning Services Grant for the "planning and designing of a Park Master Plan at Manion Park and the first phase of the construction of an All-Inclusive Playground at Manion Park." But, I believe it is appropriate for me to briefly explain the details of this current Resolution being presented to the Council at their next meeting.

If the Resolution is passed, the City of Florissant will be authorized to apply for a Planning Services Grant through the Municipal Parks Grant Commission. If the Commission approves the application for the Planning Grant, the City of Florissant will then enter into an agreement with a Recreation Planning and Design Firm to provide professional services for the completion of a Design Development Plan for Phase 2 of the redevelopment of Manion Park, which will include the All-Inclusive Playground. The professional services contract will be in the amount of \$8,000, which is currently in the 2017 Park Improvement Fund budget. The Municipal Parks Grant Commission will reimburse the City of Florissant 80% (or \$6,400) of the \$8,000.

I am respectfully requesting this information be forwarded to the City Council for their review prior to the Council Meeting on Monday, February 13th. Hopefully this will be helpful in explaining the reasoning and purpose of the Resolution.

Please do not hesitate to contact me if you have any questions or need additional information.

Thank you,

Todd Schmidt
Director of Parks and Recreation

City of Florissant
#1 James J. Eagan Drive
Florissant, MO 63033
Phone: (314) 839-7671 | Fax: (314) 839-7672
tschmidt@florissantmo.com | www.florissantmo.com

*CC to Carol
2/9/17
H
Agueta*

1 INTRODUCED BY COUNCILWOMAN PAGANO
2 FEBRUARY 13, 2017

3
4 BILL NO. 9258

ORDINANCE NO.

5
6 **AN ORDINANCE AMENDING THE GENERAL FUND BUDGET TO**
7 **REFLECT \$85,000 FROM ASSET FORFEITURE FUNDS IN ESCROW**
8 **TO FORFEITURE REVENUE ACCOUNT 01-4-34511 AND TO THE**
9 **FORFEITURE EXPENDITURE ACCOUNT 01-5-49-61000 FOR VARIOUS**
10 **POLICE DEPARTMENT EXPENDITURES.**

11
12 BE IT ORDAINED BY THE COUNCIL OF THE CITY OF FLORISSANT, ST. LOUIS
13 COUNTY, MISSOURI, AS FOLLOWS:

14
15 Section 1: The General Revenue Fund Budget is hereby amended to
16 appropriate \$85,000 from asset forfeiture funds in escrow to Forfeiture Revenue
17 Account 01-4-34511 and to Forfeiture Expenditure Account 01-5-49-61000 for
18 various police department expenditures.
19

20 Section 2: This ordinance shall become in force and effect immediately upon passage
21 and approval.

22
23
24 Adopted this ____ day of _____, 2017.

25
26
27 _____
28 Jackie Pagano
29 President of the Council
30 City of Florissant
31

32
33 Approved this ____ day of _____, 2017.

34
35
36 _____
37 Thomas P. Schneider
38 Mayor, City of Florissant
39

40
41 ATTEST:

42
43 _____
44 Karen Goodwin, MMC/MRCC
45 City Clerk
46

FLORISSANT CITY COUNCIL

AGENDA REQUEST FORM

Date: 2/3/17

Mayor's Approval:

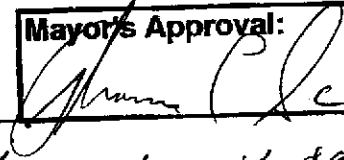

Agenda Date Requested: 2/13/17

Description of request: Request the transfer of \$85,000.00 from Forfeiture Error 1320301 to acct. 5-49610 Police Forfeiture Expenditure for anticipated expenditures per the attached memo.

Department: Police

Recommending Board or Commission:

Type of request:	Ordinances	<input checked="" type="checkbox"/>	Other	<input checked="" type="checkbox"/>
	Appropriation		Liquor License	
	Transfer	<input checked="" type="checkbox"/>	Hotel License	
	Zoning Amendment		Special Presentations	
	Amendment		Resolution	
	Special Use Transfer		Proclamation	
	Special Use		Subdivision	
	Budget Amendment			
		Y/N		Y/N

Public Hearing needed: Yes / (No)

3 readings? : Yes / (No)

Back up materials attached:		Back up materials needed:	
Minutes		Minutes	
Maps		Maps	
Memo	<input checked="" type="checkbox"/>	Memo	
Draft Ord.		Draft Ord.	

Note: Please include all attachments necessary for documents to be generated for inclusion on the Agenda. All agenda requests are to be turned in to the City Clerk by 5pm on Tuesday prior to the Council meeting.

For City Clerk Use Only:
 Introduced by: _____
 PH Speaker: _____

KGR 8/9/2006

FLORISSANT POLICE DEPARTMENT

MEMORANDUM

Date: 01-31-2017

To: Mayor Schneider

From: Chief Timothy Lowery

OK  2-3-17

Subject Money Transfer

We request the transfer of funds from account 132031 Forfeiture Escrow into account 5-49610 Police Forfeiture Expenditures for the following anticipated expenditures:

Police Motorcycle and Equipment	\$ 22,000.00
Crime Scene video Camera and Equipment	\$ 5,800.00
Bullet Proof Vests/Uniform Equipment	\$ 8,000.00
Ballistic Rifle Vests First Aid pouches and Rifle clip pouches	\$ 6,200.00
Crime Scene Investigator Training School	\$ 8,000.00
Training	\$ 10,000.00
DEA Task force undercover vehicle replacement	\$ <u>25,000.00</u>
Total	\$ 85,000.00

The total amount requested \$ 85,000.00

Chief Timothy J. Lowery

1 INTRODUCED BY COUNCILMAN SIAM
2 FEBRUARY 13, 2017

3
4 BILL NO. 9257

ORDINANCE NO.

5
6 **ORDINANCE TO AUTHORIZE AN AMENDMENT TO B-5**
7 **ORDINANCE NO. 6868 TO ALLOW FOR A NEW SIT-DOWN CARRY-**
8 **OUT RESTAURANT WITH SIGNAGE FOR THE PROPERTY**
9 **LOCATED AT 2180 N. HIGHWAY 67.**

10
11 WHEREAS, the City Council passed and approved Ordinance No. 6868 rezoning
12 Paddock Hills Shopping Center from a B-3 to B-5
13 Extensive Commercial District to allow for the location and operation of a Bob Evans
14 Restaurant; and

15 WHEREAS, the Planning and Zoning Commission of the City of Florissant has
16 recommended to the City Council at their meeting of January 17, 2017 that Ordinance No. 6868
17 be amended to allow for the addition of a sit-down, carry-out restaurant located at 2180 N. Hwy
18 67; and

19 WHEREAS, due and lawful notice of a public hearing no. 17-02-004 on said proposed
20 change was duly published, held and concluded on 13th of February, 2017 by the Council of the
21 City of Florissant; and

22 WHEREAS, the Council, following said public hearing, and after due and careful
23 deliberation, has concluded that the amendment of Ordinance No. 6868, as hereinafter set forth,
24 to be in the best interest of the public health, safety and welfare of the City of Florissant; and

25
26 NOW, THEREFORE, BE IT ORDAINED BY THE COUNCIL OF THE CITY OF
27 FLORISSANT, ST. LOUIS COUNTY, MISSOURI, AS FOLLOWS:

28
29
30 Section 1: Ordinance No. 6868 is hereby amended to allow for the addition of a sit-
31 down, carry-out restaurant located at 2180 N. Hwy 67 as described in the attached plans dated
32 12/9/16 and approved on 1/17/17 and listed below with the following stipulations:

- 33
34 a. C1-01 Cover Sheet, C2-0 Site Plan, C3-01 Landscape Plan, dated 12/9/16 by MB
35 Engineering.
36 b. **McAlister's Deli** drawings: A1.0 Floor Plan dated 12/29/16 and A2.0 Elevations, dated
37 1/4/17.

38 c. Sign Package, marked revision 1, by Design Team Sign Co., LLC, various dates.

39
40
41
42
43
44
45
46
47
48
49
50
51
52
53
54
55
56
57
58
59
60
61
62
63
64
65
66
67
68
69
70
71
72
73
74
75
76
77
78
79
80
81
82

All Alterations to the exterior, shall be implemented as indicated on the attached plans.

7. FINAL SITE DEVELOPMENT PLAN

A final site development plan shall be submitted to the Building Commissioner to review for compliance with the applicable "B-5" Planned Commercial Development ordinance prior to recording. Any variations from the ordinance approved by the City Council and/or the conceptual plans attached to such ordinance shall be processed in accordance with the procedure established in the Florissant Zoning Code.

8. AMENDMENTS TO THE SITE AND EXTERIOR BUILDING PLANS:

Any changes to the approved plans attached hereto must be reviewed by the Building Commissioner. The Building Commissioner must make a determination as to the extent of the changes per the following procedure:

1. The property owner or designate representative shall submit in writing a request for an amendment to the approved plans. The building commissioner shall review the plans for consistency with the purpose and content of the proposal as originally or previously advertised for public hearing and shall make an advisory determination.
2. If the building commissioner determines that the requested amendment is not consistent in purpose and content with the nature of the purpose as originally proposed or previously advertised for the public hearing, then an amendment to the special use permit shall be required and a review and recommendation by the planning and zoning commission shall be required and a new public hearing shall be required before the City Council.
3. If the building commissioner determines that the proposed revisions are consistent with the purpose and content with the nature of the public hearing then a determination of non-necessity of a public hearing shall be made.
4. Determination of minor changes: If the building commissioner determines that an amendment to the special use permit is not required and that the changes to the plans are minor in nature the Building Commissioner may approve said changes.
5. Determination of major changes: If the Building Commissioner determines that an amendment to the B-5 is not required but the changes are major in nature, then the owner shall submit an application for review and approval by the Planning and Zoning commission.

9. VERIFICATION PRIOR TO OCCUPANCY PERMIT

a. Any new roadway improvements shall be completed prior to the issuance of any final occupancy permit.

b. Any new storm water detention shall be completed prior to the issuance of any occupancy permit.

83 c. All fencing and/or landscaping intended as screening properties shall be completed prior
84 to the issuance of any occupancy permit, unless remitted by the Director of Public Works due to
85 weather related factors.

86
87 **10. GENERAL DEVELOPMENT CONDITIONS.**

88 a. Unless, and except to the extent, otherwise specifically provided herein, development shall
89 be effected only in accordance with all ordinances of the City of Florissant.

90
91 b. The Department of Public Works shall enforce the conditions of this ordinance in accordance
92 with the Final Site Development Plan approved by the Planning & Zoning Commission and all
93 other ordinances of the City of Florissant.

94
95 **9. PROJECT COMPLETION.**

96 Construction shall start within 90 days of the issuance of building permits for the project and
97 shall be developed in accordance of the approved final development plan within 6 months of
98 start of construction.

99
100 Section 2: Except as herein amended Ordinance No. 6868 shall remain in full force and
101 effect.

102
103 Section 3: This ordinance shall become in full force and effect immediately upon its
104 passage and approval.

105
106 Adopted this _____ day of _____, 2017.

107
108 _____
109 Jackie Pagano
110 President of the Council

111
112 Approved this _____ day of _____, 2017.

113
114 _____
115 Thomas P. Schneider
116 Mayor, City of Florissant

117
118
119 ATTEST:

120
121 _____
122 Karen Goodwin, MMC/MRCC
123 City Clerk

1 INTRODUCED BY COUNCILMAN SIAM
2 FEBRUARY 13, 2017

3
4 BILL NO. 9259

ORDINANCE NO.

5
6 **ORDINANCE AUTHORIZING A TRANSFER OF SPECIAL USE**
7 **PERMIT 7716 FROM TOT LOTS LEARNING CENTER TO**
8 **FLORISSANT KIDS CARE CENTER LLC FOR THE OPERATION OF**
9 **A DAY CARE LOCATED AT 2184 N. WATERFORD DRIVE.**

10
11 WHEREAS, the Florissant Zoning Ordinance authorizes the Council of the City of
12 Florissant, by Special Use Permit, after public hearing thereon, to permit the location and
13 operation of a day care center; and

14 WHEREAS, pursuant to Ordinance No. 7716, Antoinette Fields d/b/a Tot Lots Learning
15 Center was granted a Special Use Permit for the location and operation of a day care center
16 located at 2184 N. Waterford; and

17 WHEREAS, an application has been filed by Elizabeth Johnson to transfer the Special
18 Use Permit authorized by Ordinance No. 7716 to her name; and

19 WHEREAS, the City Council of the City of Florissant determined at its meeting on
20 February 13, 2017 that the business operated under Ordinance No. 7716 would be operated in a
21 substantially identical fashion as set out herein; and

22 WHEREAS; Elizabeth Johnson has accepted the terms and conditions set out in
23 Ordinance No. 7716.

24
25 NOW, THEREFORE, BE IT ORDAINED BY THE COUNCIL OF THE CITY OF
26 FLORISSANT, ST. LOUIS COUNTY, MISSOURI, AS FOLLOWS:

27
28
29 Section 1: The Special Use Permit authorized by Ordinance No. 7716 is hereby
30 transferred from Antionette Fields d/b/a Tot Lots Learning Center to Elizabeth Johnson d/b/a
31 Florissant Kids Care Center, LLC.

32 Section 2: The terms and conditions of said Special Permit authorized by Ordinance No.
33 7716 shall remain in full force and effect.

34 Section 3: The Special Use Permit herein authorized shall terminate if the said business
35 ceases operation for a period of more than ninety (90) days or when the named permittee ceases
36 to be the owner and operator of said business.

37 Section 4: This ordinance shall become in force and effect immediately upon its passage
38 and approval.

39
40

41 Adopted this ____ day of _____, 2017.

42
43
44
45
46
47
48

Jackie Pagano
President of the Council
City of Florissant

49 Approved this ____ day of _____, 2017.

50
51
52
53
54
55

Thomas P. Schneider
Mayor, City of Florissant

56 ATTEST:

57
58
59
60

Karen Goodwin, MMC/MRCC
City Clerk

1 INTRODUCED BY COUNCILMAN PAGANO, CAPUTA
2 FEBRUARY 13, 2017

3
4 BILL NO. 9260

ORIDNANCE NO.

5
6 **AN ORDINANCE AMENDING TITLE II CHAPTER 205 BY DELETING**
7 **SECTION 205.395 “REGULATION OF PIT BULL DOGS”**

8
9 **WHEREAS** the City Council recognizes that dangerous dogs can be of any breed; and
10 **WHEREAS** the City Council encourages the strict enforcement of the dangerous dog
11 ordinance and supports efforts to encourage responsible dog ownership.

12
13 **NOW, THEREFORE, BE IT ORDAINED BY THE COUNCIL OF THE CITY OF**
14 **FLORISSANT, ST. LOUIS COUNTY, MISSOURI, AS FOLLOWS:**

15
16 Section 1: Chapter 205 section 205.395 “Regulation of Pit Bull Dogs” is hereby deleted
17 in its entirety.

18
19 Section 3: This ordinance shall become in full force and effect immediately upon its
20 passage and approval as provided by law.

21
22 ADOPTED THIS ____ DAY OF _____, 2017.

23
24 _____
25 Jackie Pagano
26 President

27
28 APPROVED THE ____ DAY OF _____, 2017.

29
30 _____
31 Thomas P. Schneider
32 Mayor

33
34 ATTEST:

35
36 _____
37 Karen Goodwin, MMC/MRCC
38 City Clerk

1 INTRODUCED BY COUNCILMAN PAGANO, CAPUTA
2 FEBRUARY 13, 2017

3
4 BILL NO. 9261

ORIDNANCE NO.

5
6 **AN ORDINANCE AMENDING TITLE II CHAPTER 205 BY AMENDING**
7 **SECTION 205.260 "DANGEROUS ANIMALS".**
8

9 **WHEREAS** the City Council recognizes the need to improve regulations of offenses
10 involving dangerous animals; and

11 **WHEREAS** the City Council encourages the strict enforcement of the dangerous
12 animal ordinance and supports efforts to encourage responsible animal ownership.
13

14 **NOW, THEREFORE, BE IT ORDAINED BY THE COUNCIL OF THE CITY OF**
15 **FLORISSANT, ST. LOUIS COUNTY, MISSOURI, AS FOLLOWS:**
16

17 Section 1: Chapter 205 section 205.260 "Dangerous Animals" is hereby deleted in its
18 entirety and replaced with the following:

19 **Section 205.260 Dangerous Animals.**

20 [Code 1980 §4-17; CC 1990 §4-93; Ord. No. 5166, 8-27-1990; Ord. No. 6053, 12-15-
21 1997]
22

23 A. Any animal with all or any of the following characteristics may be classified as
24 dangerous by the Director of Public Works.

25 1. Any animal which has inflicted a severe or fatal injury on a human being on
26 public or private property. "*Severe injury*" means any physical injury resulting
27 directly from an animal's bite, which results in broken bones or lacerations requiring
28 extensive physician care. The victim receiving severe injuries, as defined above, must
29 provide the Director of Public Works with a signed physician's statement
30 documenting the injury and the treatment qualifying such a severe injury or sign an
31 authorization for the release of such statement. However, no animal may be declared
32 dangerous if the threat, injury or damage was sustained by a person who, at the time,
33 was committing a willful trespass or other tort upon the premises occupied by the
34 owner or keeper of the animal or was teasing, tormenting, abusing or assaulting the
35 animal or has in the past been observed or reported to have teased, tormented, abused
36 or assaulted the animal or was committing or attempting to commit a crime.

37 2. Any animal which has bitten a human being, without provocation, on public
38 or private property other than the property of the owner.

39 3. Any animal which, while on the owner's property, has bitten, without
40 provocation, a human being other than the owner or a member of the owner's family
41 who normally resides at the place where the animal is kept.

1 4. Any animal which, while off the owner's property, has inflicted a severe or
2 fatal injury on a domestic animal, livestock or poultry without provocation.

3 5. Any animal owned or harbored primarily or in part for the purpose of
4 fighting or any animal trained for fighting.

5 6. Any animal which, when unprovoked, chases or approaches a person upon
6 the streets, sidewalks or any public grounds or private property other than the
7 property of the owner in a menacing fashion, or in an apparent attitude of attack, or
8 causes a reasonable person immediate fear of personal harm or injury, regardless of
9 whether or not a person is injured by said animal.

10 7. Any animal with a known propensity, tendency or disposition to attack
11 unprovoked, to cause injury or to otherwise threaten the safety of human beings or
12 domestic animals.

13 8. The Health Department and Police Department must both prepare reports
14 documenting the details surrounding any incident when an animal inflicts a severe or
15 fatal injury.

16
17 B. No animal owned by governmental or Law Enforcement Agencies when being
18 used in the services of those agencies, as determined by the Director of Public Works
19 may be declared to be a dangerous animal.

20
21 C. If the Director of Public Works finds and declares that an animal is
22 dangerous, the owner shall be provided with written notice of this declaration. If the
23 owner cannot be located, the animal may be immediately impounded and notice shall
24 be posted on the owner's last known address. Further, if the circumstances
25 surrounding the classification as a "dangerous animal" under any of the definitions
26 listing in Subsection (A) are in dispute, then the owner has the option of submitting,
27 within five (5) working days of receipt of notice of declaration, a written request to
28 the Director of Public Works for a hearing as follows:

29 1. A hearing board, consisting of the Director of Public Works and Health
30 Supervisor or their designees, shall be convened within five (5) working days after
31 receipt of a written request.

32 2. The hearing shall be informal and strict rules of evidence shall not apply.

33 3. Pending the outcome of such a hearing, the animal must be confined in such
34 a manner so as not to be a threat to any person. The confinement may, at the sole
35 discretion of the Director of Public Works, be on the owner's premises, at the
36 Florissant animal shelter or with a licensed veterinarian at the owner's expense.

37 4. The hearing board shall determine whether to declare the animal to be a
38 "dangerous animal" based upon evidence and testimony presented at the time of the
39 hearing by the owner, in addition to witnesses, animal control personnel, Police or
40 any other person possessing information pertinent to such determination. The

1 decision of the hearing board must be unanimous in order to declare the animal to be
2 a "dangerous animal".

3 5. The hearing board shall issue and provide its findings to the owner within
4 five (5) days after the hearing. In addition, the owner shall be notified of the
5 requirements as imposed pursuant to Section 205.270 and shall advise the owner that
6 the owner has the right to appeal under the Administrative Procedure Act. The
7 dangerous animal may be subject to impoundment as provided for in this Code or,
8 alternatively, the owner or possessor of the animal found to be a dangerous animal
9 shall be required to maintain the animal as herein provided in this Code.

10
11 **Section 205.270. Dangerous Animal, Owner's Responsibility.**

12 [Code 1980 §4-19; CC 1990 §4-94; Ord. No. 6053, 12-15-1997; Ord. No. 7255 §1, 1-
13 10-2006]

14 A. The owner of an animal that has been declared a "dangerous animal" shall be
15 subject to such requirements as may be imposed by the Director of Public Works or
16 the hearing board through written notification to the owner including, but not limited
17 to, the following:

18 1. A dangerous animal which bites or scratches a human being or any animal
19 which is determined to be dangerous because of such biting or scratching of a human
20 being shall be impounded for a ten (10) day rabies quarantine in accordance with the
21 provisions of Section 205.210 of this Code.

22 2. A dangerous animal may be required to wear at all times a brightly colored
23 orange collar with large brightly colored metal tag attached to the collar so that the
24 animal can readily be identified as a dangerous animal.

25 3. The owner shall notify both the Health Department and Police Department
26 immediately if a dangerous animal is loose, unconfined or missing, has attacked
27 another animal or has attacked a human being.

28 4. The owner shall notify the Health Department within twenty-four (24)
29 hours if a dangerous animal has died or has been sold or given away. If the animal has
30 been sold or given away, the owner or keeper shall provide the Health Department
31 with the name, address and telephone number of the new owner and, if the dog is kept
32 within the City limits of Florissant, the new owner must comply with the
33 requirements of the Code.

34 5. While on the owner's property, a dangerous animal must be securely
35 confined indoors or in a securely enclosed and locked exterior pen or structure
36 suitable to prevent the entry of young children and designed to prevent the animal
37 from escaping. Such pen or structure preferably made of chain link fencing must have
38 minimum dimensions of five (5) feet wide by ten (10) feet long and five (5) feet tall
39 and must have secure sides and a secured enclosed top. If it has no
40 concrete/asphalt/paver bottom-then the sides must be embedded in the ground no less
41 than twelve (12) inches. The enclosure must also provide water and protection from
42 the elements for the animal. The enclosure, when occupied by a dangerous animal,
43 shall not be occupied by any other animal. If the dangerous animal is a female with

1 offspring under three (3) months of age, the offspring may occupy the same enclosure
2 as the mother.

3 The exterior pen or structure must not be located closer than ten (10) feet from any
4 property or fence line nor closer than twenty (20) feet from a neighboring residential
5 house.

6 A dangerous animal may be out of its pen only in the presence of a responsible adult
7 18 years of age or older and within a completely enclosed area with a fence
8 constructed in such manner as to prevent the animal from jumping over or through or
9 crawling under such fence.

10 6. No dangerous animal may be kept on a porch, patio or in any part of a
11 house or structure that would allow the animal to exit such building on its own
12 volition. In addition, no such animal may be kept in a house or structure when the
13 windows are open or when screen windows or screen doors are the only obstacle
14 preventing the animal from exiting the structure.

15 7. The owner shall display a sign on his/her premises that there is a dangerous
16 animal on the property. This sign shall be visible and capable of being read from the
17 public highway or thoroughfare from which the property is entered. In addition, a
18 similar sign is required to be posted on the kennel or pen or fenced yard of such
19 animal.

20 8. A dangerous animal may be off the owner's premises if it is muzzled and
21 restrained by a substantial chain or non-retractable leash not exceeding six (6) feet in
22 length and under the control of a responsible adult 18 years of age or older. The
23 muzzle must be made in a manner that will not cause injury to the animal or interfere
24 with its vision or respiration but must prevent it from biting any person or animal.

25 9. The owner of a dangerous animal shall present to the Health Department
26 proof that the owner or keeper has procured liability insurance in the amount of at
27 least one hundred thousand dollars (\$100,000.00) covering the three (3) year period
28 during which licensing is sought. The policy shall contain a provision requiring the
29 City of Florissant to be notified by the insurance company and the policy owner of
30 any cancellation, termination or expiration of the policy.

31 10. All owners of dangerous animals shall, within ten (10) days of such
32 declaration, register the animal with the Health Department and pay the annual
33 registration fee of \$100.00. Further the owner must provide the Health Department
34 with two (2) color photographs (one (1) showing the left profile and the other
35 showing the right profile) of the animal, clearly showing the color and approximate
36 size of the animal and any distinguishing marks or physical characteristics.

37 11. All owners of dangerous animals must have their animal microchipped
38 for permanent identification and provide the Health Department with the microchip
39 number.

40 12. All owners of dangerous animals must have their animal spayed or
41 neutered within fourteen (14) days of declarations. An owner may request an
42 exemption from the Director of Public Works to having their dangerous animal
43 spayed or neutered.

44 13. The City of Florissant Health Department and Police Department shall
45 have the authority to do random checks and six (6) month checks of all dangerous
46 animals, their location, their pen or structure, their owners, their neighbors, and
47 current insurance policies.

1 B. The owner of a dangerous animal shall comply with the requirements imposed by
2 the Director of Public Works within fourteen (14) calendar days following the
3 notification to the owner.
4

5 C. It shall be unlawful for the owner of a dangerous animal within the City of
6 Florissant to fail to comply with requirements and conditions set forth in this Chapter
7 and shall be subject to the penalties prescribed under Section 100.080 of the Code of
8 Ordinances. Any animal found to be in violation of this Code may be, in addition to
9 other penalties provided by the Municipal Code, subject to immediate seizure and
10 impoundment for a minimum of ten (10) days or the time necessary for the owner or
11 keeper to show compliance with this Code, whichever is shorter, and shall be
12 responsible for all kennel fees for the impoundment.
13

14 Section 3: This ordinance shall become in full force and effect immediately upon its
15 passage and approval as provided by law.
16

17 ADOPTED THIS ____ DAY OF _____, 2017.
18

19 _____
20 Jackie Pagano
21 President
22

23 APPROVED THE ____ DAY OF _____, 2017.
24

25 _____
26 Thomas P. Schneider
27 Mayor
28

29 ATTEST:
30

31 _____
32 Karen Goodwin, MMC/MRCC
33 City Clerk

1 INTRODUCED BY COUNCILMAN PAGANO
2 FEBRUARY 13, 2017

3
4 BILL NO. 9262

ORDINANCE NO.

5
6 **AN ORDINANCE AMENDING REVENUE ACCOUNT NO. 3490**
7 **“GRANTS AND REIMBURSEMENTS” IN THE AMOUNT OF \$9,780**
8 **AND APPROPRIATING THE SUM OF \$9,780 FROM THE GENERAL**
9 **REVENUE FUND TO BUDGET ACCOUNT NO. 4921 “UNIFORMS” TO**
10 **PURCHASE BALLISTIC VESTS AWARDED THROUGH A LOCAL**
11 **LAW ENFORCEMENT BLOCK GRANT.**

12
13 BE IT ORDAINED BY THE COUNCIL OF THE CITY OF FLORISSANT, ST. LOUIS
14 COUNTY, MISSOURI, AS FOLLOWS:

15
16 Section 1: Revenue account no. 3490 “Grants and Reimbursements” is hereby
17 amended by adding the amount of \$9,780 to reflect a grant received from the Local Law
18 Enforcement Block Grant; and

19 Section 2: There is hereby appropriated and set apart from the General Revenue Fund of
20 the City of Florissant the sum of \$9,780 to Budget Account No. 4921 “Uniforms” for the
21 purchase of Ballistic Vests for the Police Department.

22 Section 3: This ordinance shall become in force and effect immediately upon its
23 passage and approval.

24
25 Adopted this _____ day of _____, 2017.

26
27 _____
28 Jackie Pagano
29 President of the Council
30 City of Florissant

31
32 Approved this _____ day of _____, 2017.

33
34 _____
35 Thomas P. Schneider
36 Mayor, City of Florissant

37
38
39 ATTEST:

40
41 _____
42 Karen Goodwin, MMC/MRCC
43 City Clerk

FLORISSANT CITY COUNCIL

AGENDA REQUEST FORM

Date: 2/6/17 Mayor's Approval: 

Agenda Date Requested: 2/13/17

Description of request: Request an appropriation to acct 4921 in the amount of \$9780.00 for Ballistic Rifle Vests. We request this appropriation from acct 3490 General Revenue Fund. We were awarded this money from an LLEBB Block Grant.

Department: Police

Recommending Board or Commission:

Type of request:

Ordinances	X	Other	X
Appropriation	X	Liquor License	
Transfer		Hotel License	
Zoning Amendment		Special Presentations	
Amendment		Resolution	
Special Use Transfer		Proclamation	
Special Use		Subdivision	
Budget Amendment			
	Y/N		Y/N

Public Hearing needed: Yes / (No)

3 readings? : Yes / No

Back up materials attached:		Back up materials needed:	
Minutes		Minutes	
Maps		Maps	
Memo	X	Memo	
Draft Ord.		Draft Ord.	

Note: Please include all attachments necessary for documents to be generated for inclusion on the Agenda. All agenda requests are to be turned in to the City Clerk by 5pm on Tuesday prior to the Council meeting.

For City Clerk Use Only:
 Introduced by: _____
 PH Speaker: _____

FLORISSANT POLICE DEPARTMENT

MEMORANDUM

Date: 02-06-2017

To: Mayor Schneider

From: Chief Timothy Lowery

Subject Money Appropriation for Ballistic Rifle Vest Grant 2016-LLEBG-027

We request an appropriation of funds to account 4921: Uniforms in the amount of \$9,780.00. The Department applied for and received a Local Law Enforcement Block Grant (2016-LLEBG-027) to purchase 12 Rifle Grade Ballistic Vests Level III/IV in the amount of \$9,780.00 from the State of Missouri. We request the appropriation from account 3490: General Fund to complete the purchase.

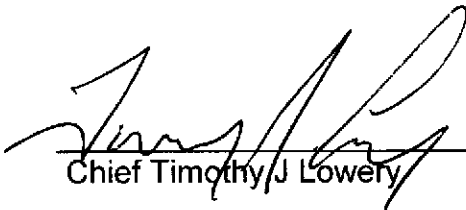

Chief Timothy J Lowery

ERIC R. GREITENS
Governor

CHARLES A. (DREW) JUDEN
Acting Director



Lewis and Clark State Building, 4th Floor
Mailing Address: P.O. Box 749
Jefferson City, MO 65102-0749
Telephone: 573-751-4905
Fax: 573-522-1908
Internet Address:
<http://www.dps.mo.gov>

STATE OF MISSOURI
DEPARTMENT OF PUBLIC SAFETY
OFFICE OF THE DIRECTOR

January 11, 2017

Capt. Randy Boden
1700 North Hwy 67
Florissant, MO 63033

Re: Project Title: Level III/IV Ballistic Vest Project
Subaward Number: 2016-LLEBG-027

Dear Capt. Boden:

Enclosed you will find the check in the amount of your federal/state share award for the above mentioned subaward number and grant title under the 2017 Local Law Enforcement Block Grant (LLEBG) program.

It is recommended that agencies establish a separate bank account for these funds in order to accurately account for any interest that may be earned, if applicable. This is not required though if your accounting system can track the deposit, expenditure, and accrued interest (where applicable) on these funds. Any interest earned on the receipt of these funds is considered "program income" and must be expended during the project period (or returned to DPS).

The project period for the 2017 LLEBG program is January 1 to June 30, 2017. Funds must be obligated within this project period, and funds must be expended no later than 60 days following the project period end date (August 29, 2017).

Your agency was approved for a specific quantity of a type of equipment. While you are allowed to purchase a different make, model, or manufacturer if so desired, you may not purchase more than the approved quantity of any type of item with grant monies. If your subaward requires a budget revision, a request must be submitted in WebGrants through the "Subaward Adjustment" component of the "My Grants" module. Subaward Adjustments must be submitted no later than 30 days prior to the end of the project period so requests will not be accepted after May 31, 2017.

Following the purchase and payment of approved equipment items, your agency is required to submit a "Status Report". In WebGrants, select "My Grants", then select your grant title, next select "Status Reports", and click "Add". Please refer to the Compliance Webinar Training posted on the DPS-LLEBG webpage at <http://dps.mo.gov/dir/programs/cjle/llebg.php> if you need a refresher following the Compliance Training on how to complete this report and the required attachments. A Status Report should be submitted immediately following the expenditure of funds but no later than September 11, 2017.

Upon submission of the Status Report, the Missouri Department of Public Safety will determine if there are any unexpended grant monies or unexpended program income monies and will contact your agency with further instructions if so.

If you have questions, please contact your DPS Internal Contact, which is identified in the "General Information" component of the grant within WebGrants.

Sincerely,

Heather Haslag
CJ/LE Program Manager

cc: File

Enclosure

TREASURER OF THE STATE OF MISSOURI

JEFFERSON CITY, MISSOURI

80-310
815

A8369780

IF NOT PRESENTED FOR PAYMENT WITHIN ONE YEAR FROM THE DATE OF ISSUANCE, THIS CHECK SHALL BE VOID. NO STATUTE 30.206

PAY EXACTLY THE SUM OF
TO THE ORDER OF

*****9,780 DOLLARS AND --00 CENTS

Account Protected via Positive Pay

CITY OF FLORISSANT-TREASURER
955 RUE ST FRANCOIS
FLORISSANT MO 63031

DATE
01-11-2017

\$ *****9,780.00



Sarah Stebbins
COMMISSIONER OF ADMINISTRATION



Eric J. Schmidt
STATE TREASURER

⑈ 18369780 ⑈ ⑆ 08 1503 10 2 ⑆ ⑈ 000 13 2004 ⑈

STATE OF MISSOURI--REMITTANCE ADVICE

SERIES A		CHECK NO. 8369780		DISTRIBUTION CK CAT: V0	
DOC. NO.	ORDER NO.	INVOICE NO.	INV. DATE	AMOUNT	
812PG029175192 PUBLIC SAFETY-OPERATING		OFFICE OF THE	DIRECTOR	9,780.00	
DATE 01-11-2017			TOTAL AMOUNT		9,780.00

The State is implementing a new eProcurement system called MissouriBUYS. Check it out at MissouriBUYS.mo.gov and begin registering in August 2015!